

Exemplar
S-Class and
X-Class Servers

DDS-2 DAT Drive Installation and Service Guide

First Edition

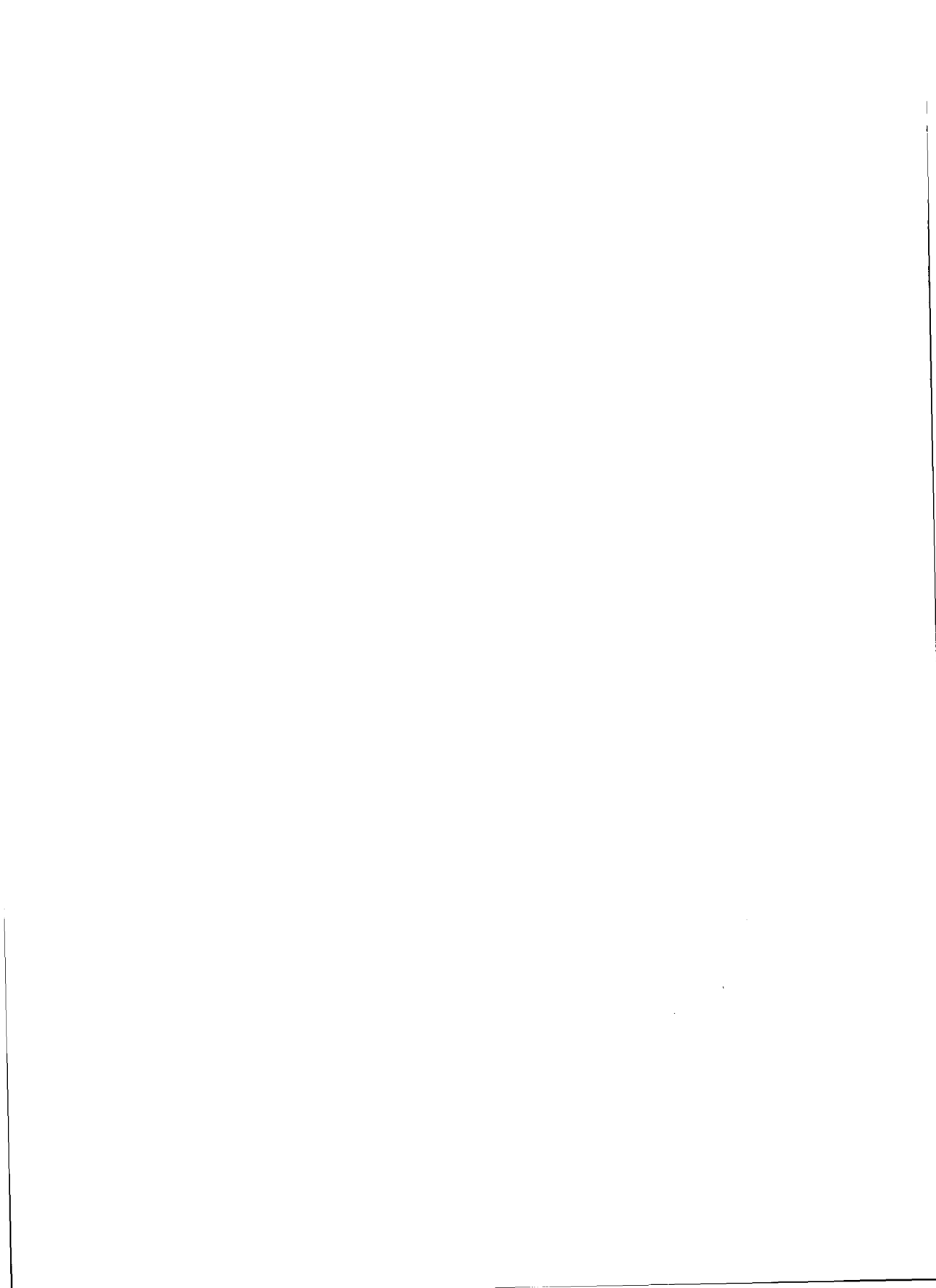

Hewlett-Packard Company
Convex Division
3000 Waterview Parkway
P.O. Box 833851
Richardson, TX 75083-3851
United States of America



DDS-2 DAT Drive Installation and Service Guide

Exemplar S-Class and X-Class Servers

A4716-90014

First Edition

January 1997

Hewlett-Packard Company
Convex Division
Richardson, Texas
United States of America

DDS-2 DAT Drive Installation and Service Guide Exemplar S-Class and X-Class Servers

A4716-90014

© Copyright Hewlett-Packard Company 1997. All Rights Reserved. Reproduction, adaptation, or translation without prior written permission is prohibited, except as allowed under the copyright laws.

Notice

The information contained in this document is subject to change without notice.

Hewlett-Packard makes no warranty of any kind with regard to this material, including, but not limited to, the implied warranties of merchantability and fitness for a particular purpose. Hewlett-Packard shall not be liable for errors contained herein or for incidental or consequential damages in connection with the furnishing, performance or use of this material.



This entire book is recyclable.

Printed in the United States of America

Revision Information for

DDS-2 DAT Drive Installation and Service Guide Exemplar S-Class and X-Class Servers

Edition	Document No.	Description
First	A4716-90014	Initial release January, 1997.



Contents

Preface	XV
Purpose and audience	xv
Notational conventions	xv
Notes, cautions, and warnings	xvi
Associated documents	xvii
Ordering documents	xvii
Technical assistance	xviii
FCC notice	xviii
Electrostatic discharge protection	xix
Antistatic packaging	xix

1 Specifications	1
Drive specifications	2
dc power requirements	3
Front panel indicator and switches	3
Drive jumpers	4
Setting the option jumpers	4
Setting the SCSI ID	5
Power supply specifications	6

2 Unpacking and inspection	9
Inspection	9
Unpacking	9
Damage claims	9

3 Installation	11
Preparation	11
Precautions	11
Electrostatic discharge (ESD)	11
Personal safety	11
Material required	12
Tools required	12
Overview of installation	12
DDS-2 DAT drive installation	13
Installing the DDS-2 DAT drive	13
Software Integration	19

4 Operation 21
Front panel indicator and switch 21
Media caution signal 22
Loading and Unloading 23
Inserting cartridges 23
Removing Cartridges 24

5 Maintenance 25
Troubleshooting 25
General procedure 25
Routine maintenance 27
Head Cleaning 27
Temperature and Condensation 28
Verifying operation 29

**6 DAT drive and SCSI cable
removal and replacement 31**
Precautions 31
Electrostatic discharge (ESD) 31
Personal safety 31
DAT drive subsystem 32
FRU (Field Replaceable Unit) part numbers 33
DDS-2 DAT drive removal and replacement 34
Tools required 34
Overview of removal and replacement 34
Removing the DDS-2 DAT drive 35
Installing the new DDS-2 DAT drive 38
Cable removal and replacement 39
DAT drive 0 SCSI cable 39
Tools required 39
Overview of removal and replacement 39
DAT drive 0 SCSI cable replacement procedure ... 40
DAT drive 0 to drive 1 SCSI jumper cable 48
Tools required 48
Overview of removal and replacement 48
DAT 0 to drive 1 SCSI jumper cable replacement
procedure 49
DAT drive 1 SCSI cable 54
Tools required 54
Overview of removal and replacement 54
DAT drive 1 SCSI cable replacement procedure ... 55

Replacing the bulkhead to embedded drive SCSI cable	62
Tools required	62
Overview of removal and replacement	62
Bulkhead to embedded drive SCSI cable replacement procedure	63

7 Power system removal and replacement 69

Precautions	69
Electrostatic discharge (ESD)	69
Personal safety	69
dc power module removal and replacement	70
Tools required	70
Overview of removal and replacement	70
dc power module replacement procedure	71
Power cable removal and replacement	76
DAT drive 0 power cable	76
Tools required	76
Overview of removal and replacement	76
DAT drive 0 power cable replacement procedure	77
DAT drive 1 power cable	84
Tools required	84
Overview of removal and replacement	84
DAT drive 1 power cable replacement procedure	85

8 SCSI SE TO DIFF converter removal and replacement 91

Precautions	91
Electrostatic discharge (ESD)	91
Personal safety	91
SCSI SE TO DIFF converter board removal and replacement	92
Tools required	92
Overview of removal and replacement	92
Removing the SCSI SE TO DIFF converter board	93
Installing the SCSI SE TO DIFF converter board.	97

Figures

Figure 1	DDS-2 front panel	3
Figure 2	Rear View of 207-000041-600 DAT DR, 5-1/4 DDS-2 SCSI BLK BZ CTD8000	4
Figure 3	Option jumper settings for DDS-2 DAT	4
Figure 4	SCSI ID settings for DDS -2 DAT drive	5
Figure 5	Diagram of dc module	7
Figure 6	Removing front skin and EMI panel	14
Figure 7	Removing the DDS-2 DAT drive blank panel	15
Figure 8	DDS-2 DAT drive cabling	16
Figure 9	Detail of EEDPB2 with dc power module	18
Figure 10	DDS-2 front panel	21
Figure 11	DDS-2 cartridge label	23
Figure 12	Inserting a cartridge	23
Figure 13	DDS-2 DAT drive cable block diagram	32
Figure 14	Removing the DDS-2 DAT drive from the drive bay	36
Figure 15	Removing the drive cage	37
Figure 16	Removing front skin, filter, and EMI panel	41
Figure 17	Removing side skin and EMI panel	42
Figure 18	Removing the DDS-2 DAT drive from the drive bay	43
Figure 19	Removing the DDS-2 DAT blank panel	44
Figure 20	DAT drive bay	46
Figure 21	Removing front skin and EMI panel	50
Figure 22	Removing the DDS-2 DAT drive from the drive bay	51
Figure 23	Removing the DAT drive blank panel	52
Figure 24	Removing front skin and EMI panel	56
Figure 25	Removing side skin and EMI panel	57
Figure 26	Removing the DAT drive from the drive bay	58
Figure 27	DAT drive bay	60
Figure 28	Removing front skin and EMI panel	64
Figure 29	Embedded Disk drive configuration	65
Figure 30	Removing front skin, filter, and EMI panel	72
Figure 31	Left front chassis detail	73
Figure 32	Detail of EEDPB2 with dc power module	75
Figure 33	Removing front skin and EMI panel	78
Figure 34	Removing side skin and EMI panel	79
Figure 35	Removing the DAT drive from the drive bay	80
Figure 36	Removing the DAT drive blank panel	81

Figure 37	DAT drive bay	82
Figure 38	Removing front skin and EMI panel	86
Figure 39	Removing side skin and EMI panel	87
Figure 40	Removing the DAT drive from the drive bay	88
Figure 41	DAT drive bay	89
Figure 42	Removing front skin and EMI panel	94
Figure 43	Embedded Disk drive configuration	95
Figure 44	SCSI SE TO DIFF converter (201-000004-201) jumpers	97

Tables

Table 1	Drive Specifications	2
Table 2	DDS-2 DAT drive dc power requirements.	3
Table 3	Power supply characteristics	6
Table 4	Power supply voltage specifications.	6
Table 5	550-001016-201 ASSY, DAT DRIVE, SECOND EXCALIBUR U/A	12
Table 6	Indicator LED operation	22
Table 7	DDS-2 DAT drive FRU list	33
Table 8	Option jumper settings for SE TO DIFF converter board	97

Preface

Purpose and audience

The *DDS-2 DAT Drive Installation and Service Guide* provides information for installing and maintaining a DDS-2 DAT drive in Hewlett-Packard Exemplar S-Class and X-Class Technical Servers. It is intended for anyone installing or servicing the DDS-2 drive, including:

- Hewlett-Packard customers
- Hewlett-Packard Customer Engineers
- Hewlett-Packard CXD TAC

Notational conventions

This section discusses notational conventions used in this book.

Bold monospace

In command examples, text shown in **bold monospace** identifies user input that must be typed exactly as shown.

Monospace

In paragraph text, **monospace** identifies command names, system calls, and data structures and types.

In command examples, **monospace** identifies command output, including error messages.

In command syntax diagrams, text shown in **monospace** must be typed exactly as shown.

Italic

In paragraph text, *italic* identifies new and important terms and titles of documents.

In command syntax diagrams, *italic* identifies variables that must be supplied by the user.

{ }

In command syntax diagrams, text surrounded by curly brackets indicate a choice. The choices available are shown inside the curly brackets and separated by the pipe (|) sign. The following command example indicates that you can enter either a or b:

```
command {a | b}
```

[]

In command syntax diagrams, square brackets indicate optional data.

The following command example indicates that the variable *output_file* is optional:

```
command input_file [output_file]
```

...

In command syntax, horizontal ellipsis shows repetition of the preceding item(s).

The following command example indicates you can optionally specify more than one *input_file* on the command line.

```
command input_file [input_file...]
```

Notes, cautions, and warnings

This document presents notes, cautions, and warnings in the following formats.

Note

A Note highlights supplemental information.

Caution

A Caution highlights information necessary to avoid damage to the system.

Associated documents

For more information on the Hewlett-Packard Exemplar S-Class and X-Class Technical Servers, you can order these books from Hewlett-Packard:

- *Exemplar Site Preparation Guide S-Class Server* (A471-90005). This book provides technical information needed to prepare a site for the installation of an Exemplar S-Class Technical Server.
- *Exemplar Installation Guide S-Class Server* (A4716-90003). This book provides technical information and detailed procedures needed to install an Exemplar S-Class Technical Server.
- *Exemplar Diagnostics Guide S-Class and X-Class Server* (A4716-90002). This book provides an overview of all diagnostic programs. It also provides the user with definitive descriptions of the purpose of each test and defines minimum hardware configurations required for testing.
- *Exemplar Maintenance Guide S-Class and X-Class Servers* (A4716-90004). This book is intended as a reference for system support engineers and manufacturing test personnel, as well as those customers that perform their own system maintenance.

Ordering documents

To order the current edition of these or any other documents concerning Hewlett-Packard Exemplar S-Class or X-Class Technical Servers, send requests to:

Hewlett-Packard Company
Convex Division
Customer Service
P.O. Box 833851
Richardson TX 75083-3851 USA

Please include the document number or the exact title of the document.

Technical assistance

If you have questions that are not answered in this book, contact the Hewlett-Packard CXD Technical Assistance Center (TAC) at the following locations:

Within the continental U.S., call 1 (800) 952-0379.

From Canada, call 1 (800) 345-2384.

All other locations, contact the local Hewlett-Packard office.

You can also use the contact utility, if you would like to report any problems you may have.

FCC notice

This equipment generates, uses and can radiate radio frequency energy. If the equipment is not installed and used in strict accordance with the instruction manual, it may cause interference to radio communications.

This equipment has been tested and found to comply with limits for a Class A digital device, pursuant to Part 15 of the FCC Rules. These limits are designed to provide reasonable protection against harmful interference when equipment is operated in a commercial environment.

When this equipment is operated in a residential area, it is likely to cause interference. In this case, the interference must be corrected at the operator's expense.

Do not connect external equipment to the utility outlets in the Hewlett-Packard Exemplar S-Class and X-Class Technical Server. Unauthorized connection voids all agencies' emissions certification.

Electrostatic discharge protection

The DDS-2 DAT drive and related assemblies are sensitive to static electricity. Although some devices such as metal-oxide semiconductors are extremely sensitive, all semiconductors, as well as some resistors and capacitors, may be damaged or degraded by exposure to static electricity.

Electrostatic damage to electronic devices may be caused by the direct discharge of a charged conductor or by exposure to the static fields surrounding charged objects.

Caution

Do not service the equipment before observing the following precautions:

- Ground yourself to the peripheral node or a grounded service area whenever working on the DDS-2 DAT drive or related assemblies, or whenever electronics will be exposed. Connect yourself to ground with a wrist strap. Connection may be made to any grounded metal assembly in the peripheral cabinet. Remember that you and the electronic devices must both be grounded to avoid potentially damaging static discharges.
- Turn off power before removing or installing power cords.
- Do not remove any circuit boards from the drive.
- Never use an ohmmeter on any DDS-2 DAT drive circuit board.

Antistatic packaging

Hewlett-Packard Company products arrive in a specially designed bag that dissipates static electricity and serves as a shield against electrostatic fields while in transit. This bag should be retained and used to store the product if it is removed from the system for any reason.

The bag is not designed for use as a static dissipating mat. Do not use the antistatic bag for any other purpose than to enclose a product.

Holes in the bag render it useless as an antistatic measure. Therefore, it should always be completely closed and sealed when it contains a product. Any bag that shows damage or wear should immediately be discarded and replaced.

Product Type:

DDS-2 DAT drive

Part Number:

207-000041-600

This chapter discusses the features and the electromechanical and physical specifications of the Hewlett-Packard Exemplar S-Class and X-Class Technical Server DDS-2 DAT drive.

The DDS-2 DAT drive (Part Number 207-000041-600) is used as a backup and media installation device in the Hewlett-Packard Exemplar S-Class and X-Class Technical Server Family.

The DDS-2 DAT drive uses a SCSI-2 interface and provides 4 GB of storage.

Drive specifications

Table 1 contains the basic specifications for the DDS-2 DAT drive.

Table 1 Drive Specifications

Characteristics	Conditions	Specifications
Size of DDS-2 DAT drive (Part Number 207-000041--600)	Width	5.9 in. (146 mm)
	Height	1.6 in. (41 mm)
	Length	7.1 in. (180mm)
	Weight	2.4 lb (1.1 kg)
Interface		SCSI-2 single-ended, asynchronous or synchronous
Capacity 395 ft. (120 m) tape		4 GB
Physical	Head configuration	2 read heads, 2 write heads
	Cartridge	2.9 in. x 2.1 in. x 0.4 in.
Transfer rate		400 KB/sec
Burst rate		5 MB/sec
Tape speed		0.47 inches/sec (11.9 mm/sec)
Head to tape speed		270 inches/sec (6,858 mm/sec)
Search/rewind speed		200x normal speed
Average access time	120 meter tape	40 seconds
Recording method		Helical scan (R-DAT)
Recording format		DDS-2, ANSI/ECMA DDS-DC
Environmental requirements	Operating temperature	41° F to 113° F (5 C to 45° C) mechanism and media
	Operating humidity	20% to 80% noncondensing Maximum wet bulb of 878.8° F (26° C)

dc power requirements

The DDS-2 DAT drive uses +5 Vdc and 12+ Vdc. Table 2 contains the dc power specifications for the DDS-2 DAT drive.

Table 2 DDS-2 DAT drive dc power requirements

Power requirements	Supply voltage	
	+5 V	+12 V
Current		
Operating current	770 ma	400 ma
Idle current	700 ma	.5 amp
Peak	1.1 amps	1.6 amps
Voltage		
Regulation	$\pm 7\%$	$\pm 10\%$
Ripple (peak to peak)	≤ 50 mV	≤ 100 mV
Power consumption	Below 8.7 watts (typical)	

Front panel indicator and switches

The front panel contains two indicator LEDs and an eject button. Figure 1 shows the front panel components.

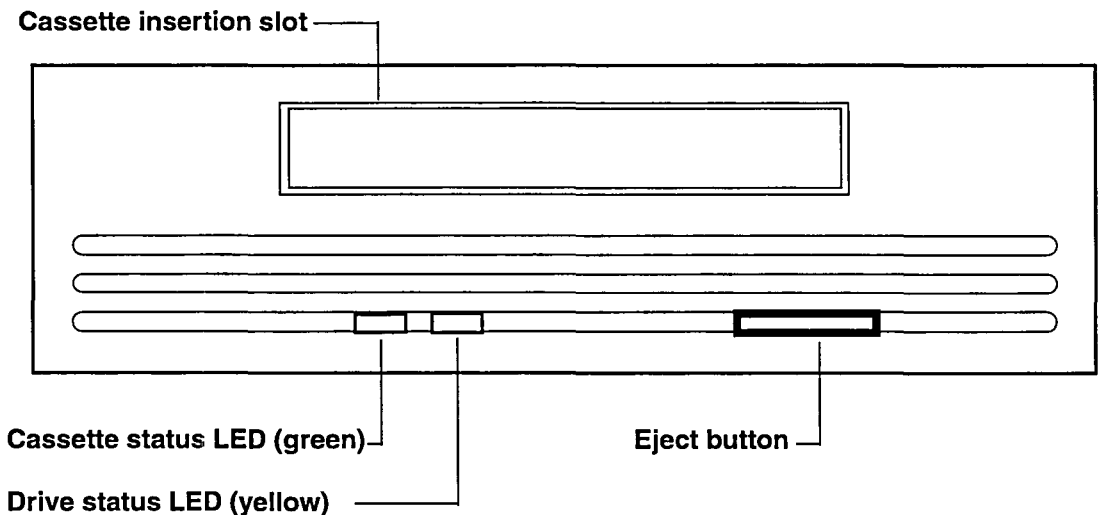

Figure 1 DDS-2 front panel

Drive jumpers

The SCSI ID and configuration options are set with the jumpers on a single jumper block located beside the SCSI connector at the rear of the drive, as shown in Figure 2.

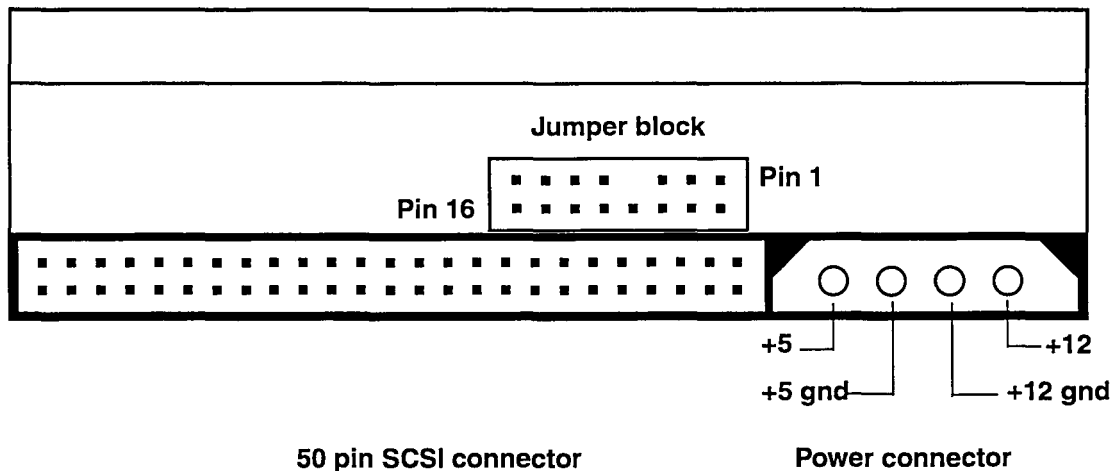

Figure 2 Rear View of 207-000041-600 DAT DR, 5-1/4 DDS-2 SCSI BLK BZ CTD8000

Setting the option jumpers

The SCSI termination power, data compression, and self-test functions are set using pins 8-16 of the jumper block. Figure 3 describes the jumper block pin assignments.

Figure 3 Option jumper settings for DDS-2 DAT

Pins	Function	Default configuration ¹
15 & 16	Termination power on	ON
13 & 14	No connection	OFF
11 & 12	Active terminator enabled	OFF
9 & 10	Data Compression disabled	ON
8 & 10	Power-on self test enabled	OFF
1 - 6	SCSI ID bits	

1. Default configuration is subject to change. See Conner DAT drive Model CTD8000R-S Configuration Document 207-000041-600

Setting the SCSI ID

The default setting for the first DDS-2 DAT drive is SCSI ID 0. If a second DDS-2 DAT drive is installed it should be set to SCSI ID 1. The SCSI ID can be set using jumper pins 1 through 6, as shown in Figure 4.

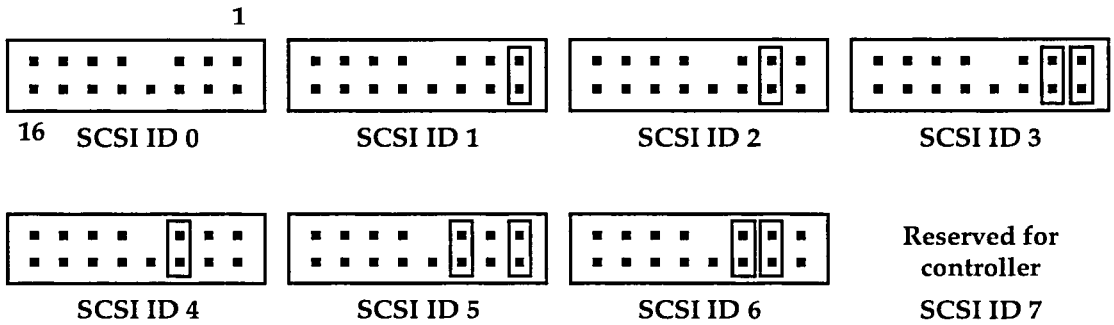

Figure 4 SCSI ID settings for DDS-2 DAT drive

Power supply specifications

AT&T Microelectronics manufactures the TW070AB DiskPower Converter used with the DDS-2 DAT drive drive in the Hewlett-Packard Exemplar S-Class and X-Class Technical server. The TW070AB DiskPower Converter module (dc power module) mounts to the Excalibur Embedded Disk Power Board (EEDPB2).

Table 6 contains the power supply characteristics and Table 7 shows the power supply output voltage specifications.

Table 3 Power supply characteristics

Parameter	Condition	Limits
Operating input voltage		36 Vdc to 72 Vdc
Maximum input current	Steady state	1.5 A maximum
	During spin-up surge	2.6A maximum
	Start-up current	2.2 A maximum
Output overvoltage shutdown	5.40 V minimum	6.00 V maximum
	12.75 V minimum	14.0 V maximum
Operational environment	Operational altitude	-200 ft (-60m) to 8000 ft (2500m)
	Operational temperature	0° C to + 50° C
	Storage temperature	-40° C to + 85° C
	Relative humidity	5 to 95%
Weight		2.5 oz. (71g)

Table 4 Power supply voltage specifications

Output voltage	+ 5 Vdc	+12 Vdc
Minimum output voltage	4.85 Vdc	11.64 Vdc
Maximum output voltage	5.25 Vdc	12.60 Vdc
Output current - Maximum	2.2A	2.5 A
Output ripple and noise pk-pk (5 Hz to 20 Hz)	50 mV	60 mV
Output voltage regulation	0.3%	0.3%

See Figure 5 for a diagram of the dc power module.

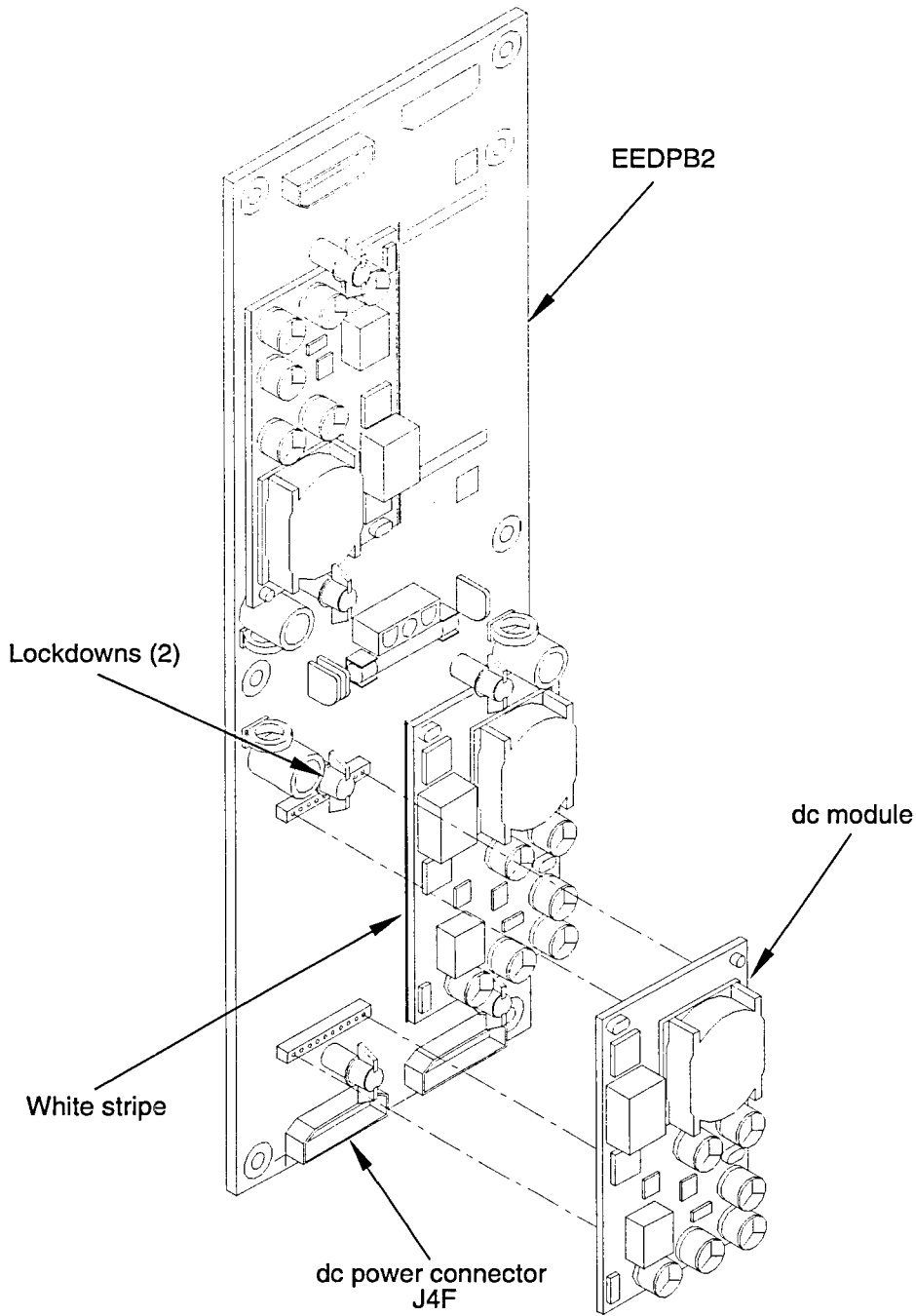

IOEXS046
12/16/08

Figure 5 Diagram of dc power module

This chapter describes unpacking and inspecting the DDS-2 DAT drive prior to installation.

Inspection

All shipping containers are designed to protect their components under normal shipping conditions. Carefully inspect each carton for signs of shipping damage before it is unpacked. If damage is found after visual inspection, document the damage with photographs and contact the transport carrier immediately.

Unpacking

The customer's bill of materials lists all equipment shipped from Hewlett Packard. It should be used as a checklist to ensure that all equipment has arrived. Use the following procedure to unpack the shipping container:

- Step 1** Remove each item from its shipping container.
- Step 2** Inspect each item as it is unpacked for any signs of shipping damage.
- Step 3** If equipment damage is found, document the damage with photographs, and proceed to the next section.
- Step 4** Save all packing material until after operational checkout of the equipment. This enables equipment to be returned safely to Hewlett Packard if required.

Damage claims

If the equipment is damaged, a damage claim form must be completed. Damage claims should be completed by the customer and given to the shipping representative. Claim forms are normally obtained from the shipping representative.

This chapter describes how to install the secondary DDS-2 DAT drive in Exemplar S-Class and X-Class Servers.

Preparation

This section outlines the preparations necessary before beginning installation of the secondary DDS-2 DAT drive.

Precautions

Protect personnel and equipment when installing any Hewlett-Packard Company product by always taking proper precautions.

Electrostatic discharge (ESD)

Prepare an ESD safe work surface large enough to accommodate the DDS-2 DAT drive assembly.

Observe the electrostatic discharge procedures described in the "Electrostatic discharge protection" section on page xvii, to prevent damage to the drive during installation.

Personal safety

Always insure that both the front panel and the power controller are turned off before removing or installing any components in the Exemplar S-Class and X-Class Technical Server.

Remove the front panel key after shutting the system down to prevent inadvertent power-on during installation.

Material required

Table 5 contains a list of material included in the 550-001016-200, ASSY, DAT DRIVE, SECOND EXCALIBUR U/A kit.

Table 5 550-001016-201 ASSY, DAT DRIVE, SECOND EXCALIBUR U/A

Description	Part number
DAT DR, 5 -1/4" DDS-2 SCSI BLK BZ CTD8000	207-000041-200
CONV, DC/DC 48V TO 5/12V 70W PEAK, W/DOT	200-001058-201
MFAB, PERIPHERAL CHASSIS, 3.5 DRIVE	325-000209-500
SCR, M3-.5 X 6 FLH, PHH. STZN	310-005203-001

Tools required

The following tools are required to complete the procedures in this chapter.

- Phillips screwdriver
- Personal grounding system
- Static dissipating mat

Overview of installation

Installing a DDS-2 DAT drive and the accompanying dc power module involves some minor disassembly of system assemblies.

The following list provides a summary of the steps involved in the installation process.

Note

This list is intended for summary purposes only; detailed installation instructions are presented in the "DDS-2 DAT drive installation" section on page 13.

- Step 1** Shut down the system.
- Step 2** Remove the front skin, filter, and Electromagnetic Interference (EMI) panels.
- Step 3** Remove the LCD control panel.
- Step 4** Remove the DDS-2 DAT drive blank panel assembly from the chassis.
- Step 5** Attach the SCSI cable to the rear of the drive.
- Step 6** Attach the power cable to the rear of the drive.
- Step 7** Install the DDS-2 DAT drive assembly into the bay.

- Step 8** Install the LCD control panel.
- Step 9** Install the EEDPB2 dc power module.
- Step 10** Reboot the system and verify DDS-2 DAT drive operation.
- Step 11** Install the EMI panel, filter, and front skin.
- Step 12** Integrate DAT drive using OpenBoot commands.

DDS-2 DAT drive installation

The following sections provide detailed instructions on installing the secondary DDS-2 DAT drive.

Installing the DDS-2 DAT drive

To install the DDS-2 DAT drive, perform the following steps:

- Step 1** Shut down the system with the `/etc/shutdown` command.

The *time* argument can be used to schedule a timed shutdown or the keyword "now" can be used to shut down the system immediately.

```
/etc/shutdown -h now
```

- Step 2** Remove power to the system by turning the keyswitch on the operator panel to the OFF position.

Caution

Do not attempt to install the DDS-2 DAT drive before removing power to the cabinet. Failure to remove power before installing the DDS-2 DAT drive will damage electronic components on the drive assembly.

- Step 3** Remove the front cabinet skin by pulling from the top and bottom of the skin until it pops out as shown in Figure 6.
- Step 4** Remove the filter from the front of the chassis as shown in Figure 6.
- Step 5** Remove the front EMI panel by unfastening the screws securing the panel. See Figure 6.

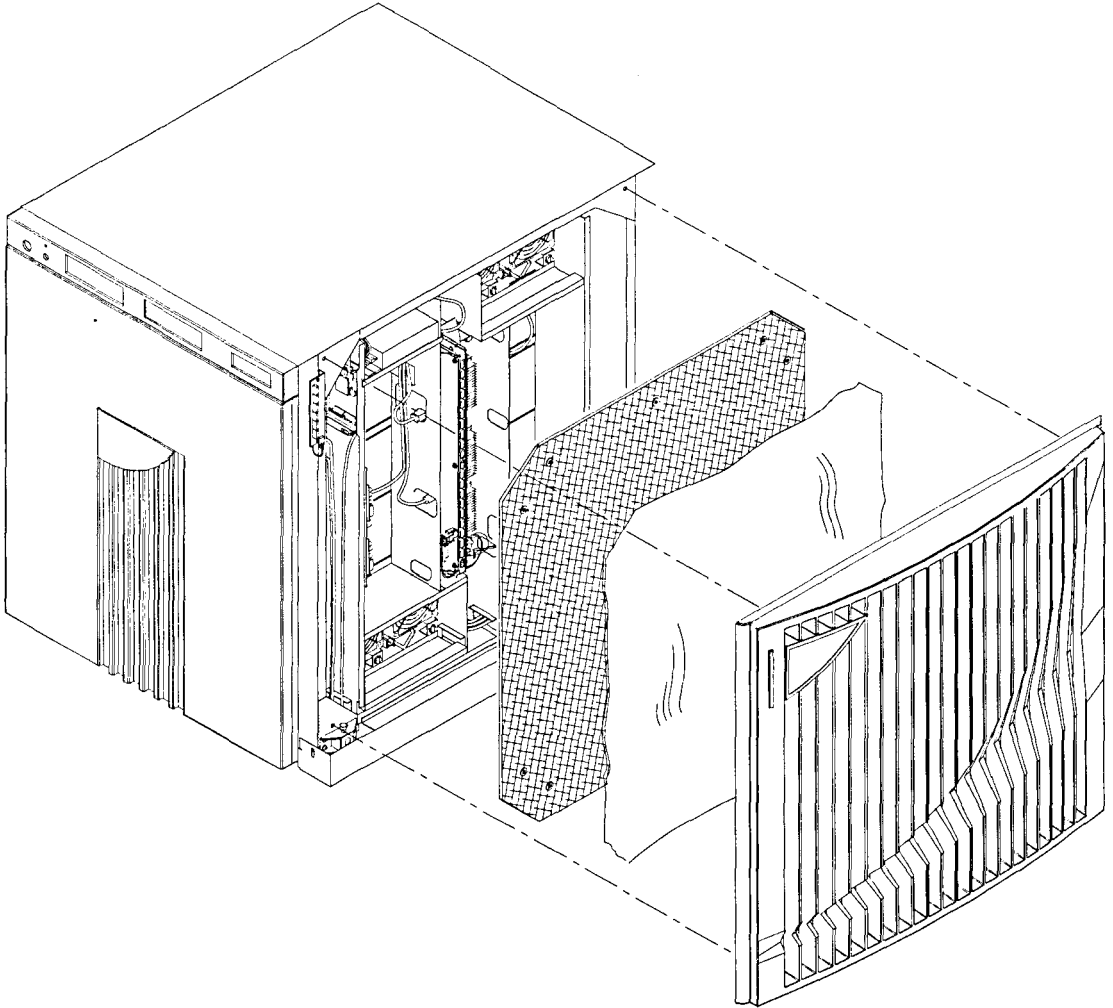

EXSM056
12/17/96

Figure 6 Removing front skin and EMI panel

- Step 6** Remove the LCD control panel by removing the four screws securing the panel. Carefully place the LCD control panel on top of the chassis.

- Step 7** Remove the DDS-2 DAT drive blank panel from the chassis by removing the two screws that secure the panel. See Figure 7.

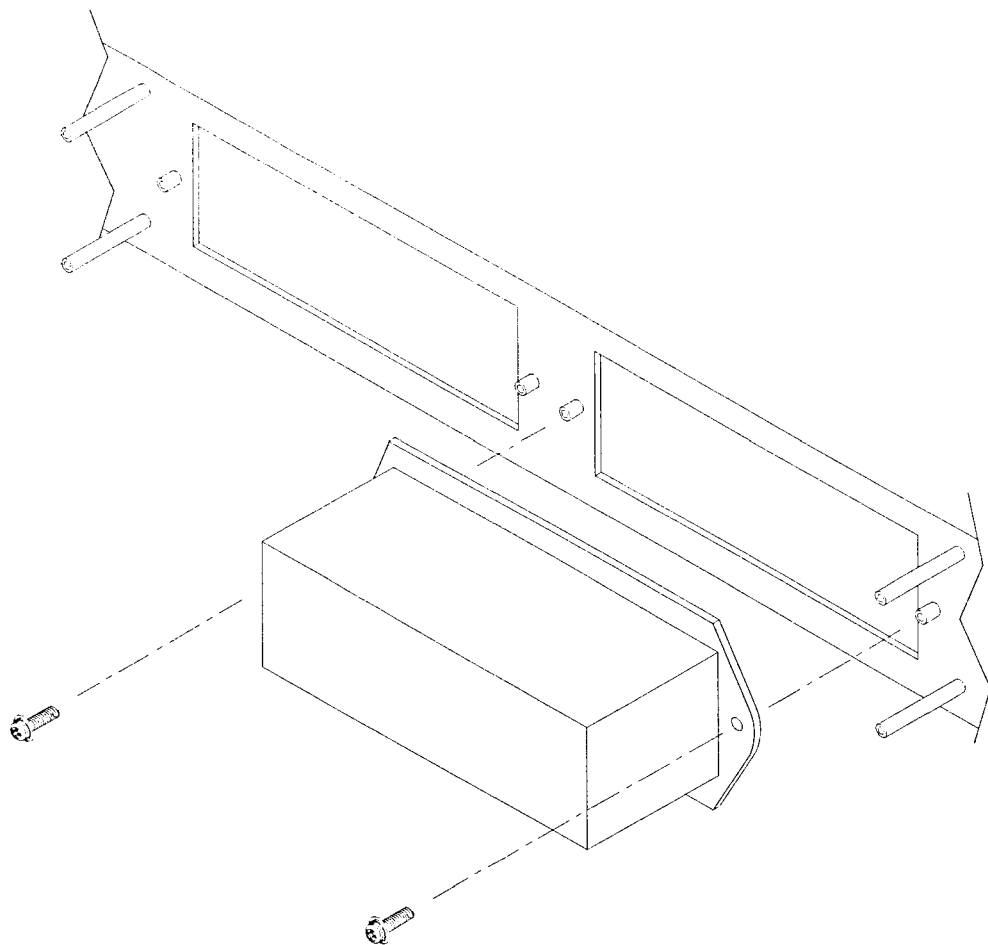
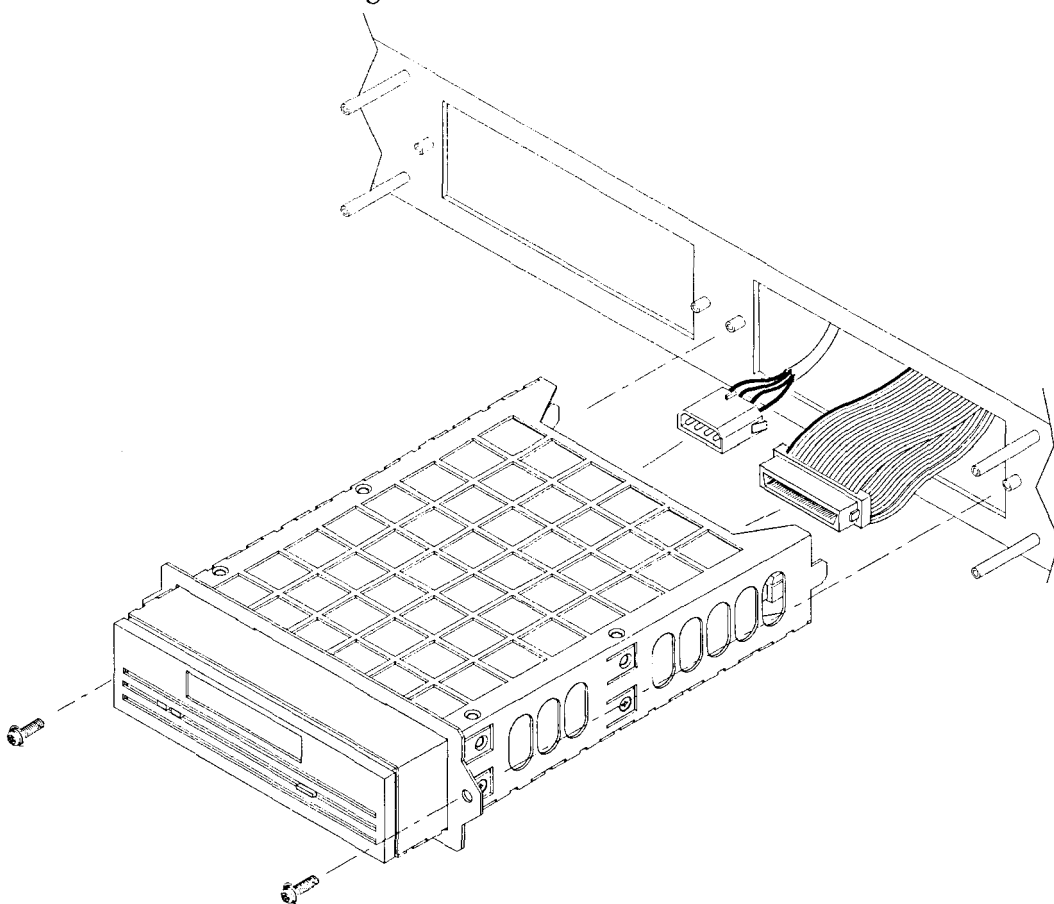

Figure 7 Removing the DDS-2 DAT drive blank panel

- Step 8** Locate the factory-installed SCSI and power cables in the drive bay and lay them so that they extend out the front of the drive bay.

- Step 9** Attach the SCSI cable to the back of the DDS-2 DAT drive. See Figure 8.
- Step 10** Attach the power cable to the back of the DDS-2 DAT drive. See Figure 8.



IOEXS041
12/10/98

Figure 8 DDS-2 DAT drive cabling

- Step 11** Slide the DDS-2 DAT drive cage assembly into the drive bay. The SCSI cable and power supply cable should fold up and over the top of the drive and lay flat.
- Step 12** Mate the tabs on each side of the DDS-2 DAT drive cage assembly with the corresponding slots in the back wall of the drive bay.
- Step 13** Secure the DDS-2 DAT drive cage assembly with two screws.
- Step 14** Install the LCD control panel using four screws.

Step 15 Locate the EEDPB2 mounted on the left chassis side panel just below the embedded disk drive.

You must install the dc power module for the secondary DDS-2 DAT drive in the position marked "POWER BOARD EXT FRONT" on the EEDPB2 board. See Figure 9.

Step 16 Orient the dc power module as shown in Figure 9.

Caution

Do not install the dc power module incorrectly. Damage to the dc module will occur.

Step 17 Mount the dc power module flush with the edge of the EEDPB2 to ensure that both connectors on the module mate properly.

Step 18 Secure with the lockdowns as shown in Figure 9.

Step 19 Install the EMI panel, filter, and front skin.

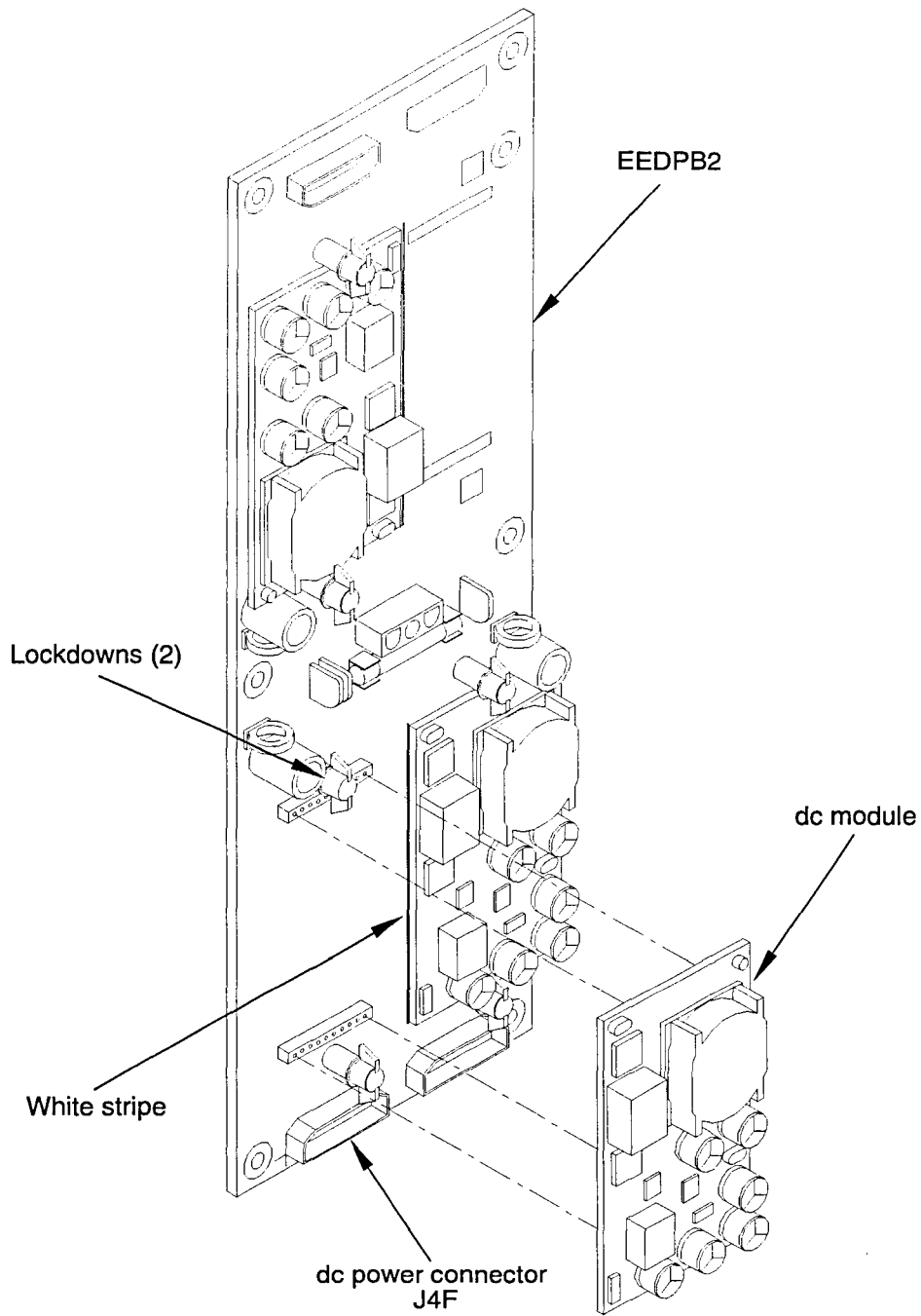

IOEXS046
12/16/96

Figure 9 Detail of EEDPB2 with dc power module

Software Integration

This section contains a summary of procedures used to integrate a DDS-2 DAT drive as the second DDS-2 DAT drive in the system.

When you add a device to your system or change characteristics of an existing one, you must integrate the device into SPP-UX.

Defining the DDS-2 DAT drive with OpenBoot commands

Before booting the nodes of your Exemplar system, you must specify a logical unit number for the second DDS-2 DAT drive to OpenBoot. Steps 1 through 4 detail this process.

Perform the following steps to define the DDS-2 DAT drive:

Step 1 Restart the system by turning on the keyswitch on the operator panel.

Step 2 When the system has booted to the OPB prompt, go to the Exemplar System Console window and determine the full device name with the `show-devs` command. Enter

```
ok show-devs
```

at the OpenBoot `ok` prompt. `show-devs` with no argument displays all devices known on the specified hypernode.

Step 3 Find the device path that includes the *string* `st` (SCSI tape) in the output from the `show-devs` command as shown in the following output example:

```
/pci@fe, 10000/q1isp@0, 0/st@1,0
```

Step 4 Define the SPP-UX logical-unit to physical-unit mapping using `mkmap`.

`mkmap` has the following syntax:

```
mkmap -n logical_unit_number ststring
```

where

```
mkmap
```

Defines an SPP-UX logical-unit to physical-unit mapping. This mapping is a label for tape and network devices that cannot be labeled like disks.

```
-n
```

Creates a logical-unit property with no physical unit information; this option should only be used with network adaptors.

logical_unit_number

Designates the logical-unit number of each tape device.

ststring

Represents the full device path.

Create the database maps by entering *logical_unit_number* and the device path (*ststring*) by using the `mkmap` command.

```
ok mkmap 1 /pci@fe, 10000/qlisp@0, 0/st@1,0
```

Step 5 Use the `show-map` command to verify the logical unit is correct.

```
ok show-map
```

```
Flag  Unit  Device  Pathname
      1    /pci@fe, 10000/qlisp@0, 0/st@1,0
```

Reset the OBP so that the device tree is probed and built with the new logical unit number in place.

```
ok reset
```

Front panel indicator and switch

The front panel contains two indicator LEDs and an eject button. Figure 10 illustrates the front panel components.

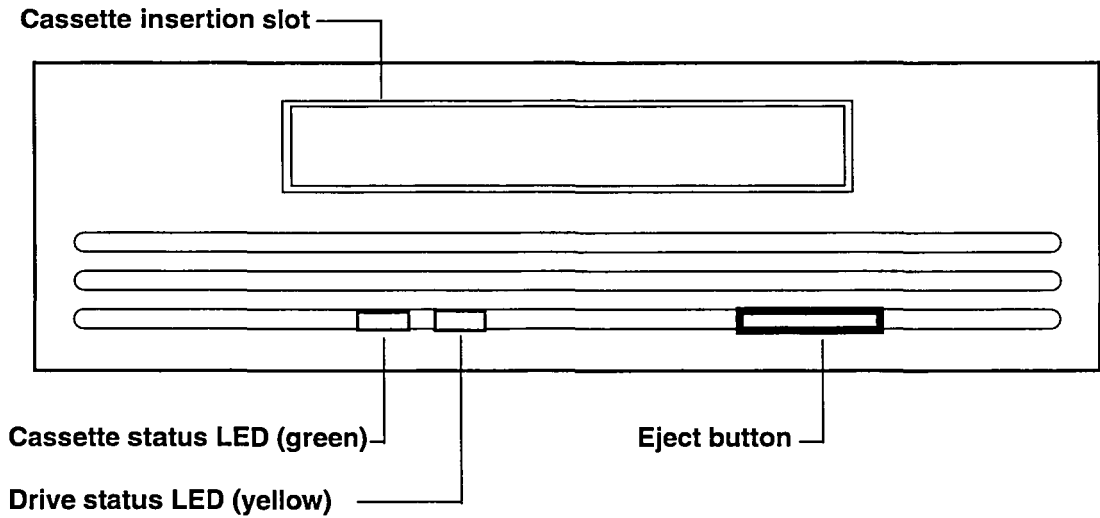

Figure 10 DDS-2 front panel

The two indicators provide operating information for normal as well as error conditions. Table 6 shows the meaning of the different LED patterns.

Table 6 Indicator LED operation

Cassette status LED (green)	Drive status LED (yellow)	Meaning
	ON	The drive is reading or writing the tape.
	Flashing rapidly	A hardware fault occurred, or dew (excessively high humidity) was detected.
ON		A cartridge is loaded and does NOT generate excess errors.
Flashing slowly		Media caution signal. Indicates that a cartridge is near the end of its life or that the heads need cleaning.
Flashing slowly	Flashing	A prerecorded DDS cartridge is loaded and is being played automatically.
Flashing rapidly		The drive could not write to the tape correctly. (maximum rewrite count exceeded) Use a DDS DAT cleaning cartridge to clean the heads.

Caution

Do not push the eject button while this LED is ON. If you do, the operation in progress is aborted and the cartridge is ejected, possibly causing a loss of data.

Media caution signal

The number of correctable errors that occur during reading and writing is monitored. If the number of errors grows excessive, it can mean that the tape is nearing the end of its useful life, or that the tape heads need cleaning.

If the Media Caution signal appears, clean the tape heads as described in "Head Cleaning" section on page 27.

If the signal is still displayed after cleaning the heads, repeat the operation with a different tape. If this clears the signal, the first tape is nearing the end of its life. Copy the data onto a new tape and discard the old one.

The Media Caution signal is cleared when a new tape is loaded or when the drive is power-cycled.

Loading and Unloading

This section explains loading and unloading a cartridge under normal operating conditions. It also explains the manual procedure for removing a cartridge abnormally lodged in the drive. Under a few exceptional conditions—such as a power outage, you may need to manually unload a cartridge.

Inserting cartridges

Only use cartridges labelled with a DDS logo in the drive—never use DAT cartridges. Figure 11 illustrates the DDS-2 logo.

Figure 11 DDS-2 cartridge label



Caution

Do not stick a label on top of another label. Stick cartridge labels firmly to the recessed label area. To avoid a mechanism jam, remove any labels that are peeling off, and stick labels only within the label area.

Insert a cartridge into the slot on the front panel with the arrow on the top of the cartridge entering the slot first. Push against the middle part of the cartridge until it is fully recessed into the cartridge insertion slot.

As the cartridge is inserted, the drive takes it and performs a load sequence. Figure 12 shows the proper orientation of a data cartridge as it is inserted into the drive.

Figure 12 Inserting a cartridge

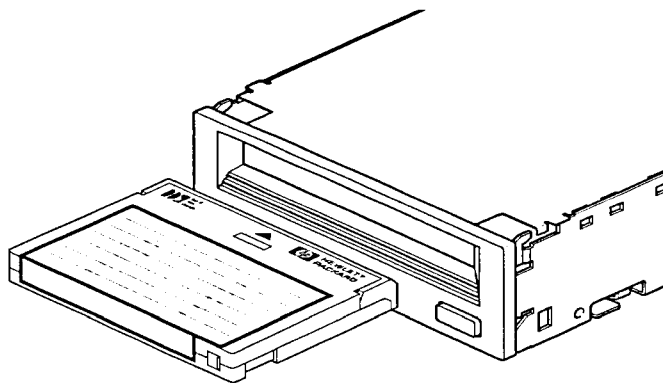

Note

By default, the drive is configured to detect DDS Media Recognition System cartridges. If you load a cartridge which is not DDS Media Recognition System, the cartridge will be treated as write-protected; you will only be able to read it, not write to it.

The load sequence is as follows:

- The drive mechanism threads the tape and rewinds to BOM (Beginning of Media). The drive then reads the first Reference area on the tape (Partition 1 on a 2-Partition tape) to find the tape format (DDS, audio, and so on) and the number of partitions.
- If the tape is blank, the drive leaves the tape at BOP (Beginning of Partition) for Partition 0 and awaits the next command.
- If the error rate is high, the Media Caution signal is set on the front panel lights (the Attention light flashes amber).
- The System area on the tape is then accessed and the Tape log read into the drive.
- Finally the drive rewinds to BOP (Partition 0).

Removing Cartridges

A cartridge can be removed either in response to a SCSI LOAD/UNLOAD command or if you press the Unload button.

For either of these methods the drive performs an Unload sequence:

- The tape is rewound to BOP for Partition 0.
- If the tape is write-enabled, the copy of the Tape log is written back to tape.
- The tape is then rewound to BOM, unthreaded from the mechanism, and ejected.

If the host has previously sent a PREVENT MEDIA REMOVAL command, operation of the Unload button is disabled; pressing the button has no effect, and does not initiate an Unload sequence. The Unload button returns to normal operation when the drive receives an ENABLE MEDIA REMOVAL command or a SCSI reset.

This chapter contains the troubleshooting information and maintenance procedures for the DDS-2 DAT drive used in Exemplar S-Class and X-Class Servers.

Troubleshooting

The DDS-2 DAT drive is a single Field Replaceable Unit (FRU) and does not contain any field-serviceable parts. Troubleshooting procedures described in this section are limited to verifying that the DDS-2 DAT drive is installed properly and that valid media is used.

General procedure

If a problem occurs, the first step is to try to establish whether the problem lies with the cartridge, the drive, the host computer and connections, or the way the system is being operated.

- Has the drive been recently installed?

There could be an installation problem:

- Check the power connectors and SCSI cabling.
 - Is the SCSI ID correctly set? Is there a SCSI system conflict?
 - Has the SCSI bus been correctly terminated?
 - Have the configuration switches been set correctly for your system?
 - Check the environmental conditions against the specified limits.
- Are you using new cartridges or a different brand of cartridge? Have you been using the particular cartridge for a very long time?

The problem could lie with the cartridge:

- Check that you are using a DDS-labeled cartridge—not a DAT cartridge.
 - DDS-3 media are ejected by DDS-1, DDS-DC, and DDS-2 drives.
 - Are you trying to write to non-MRS media? Check the configuration switches.
 - Has the cartridge been write-protected?
 - Clean the tape heads with a cleaning cartridge. For more information on cleaning the heads see “Head Cleaning” section on page 27.
 - Try the operation again.
 - If the problem still occurs, try using a different cartridge.
 - If the problem continues, the problem probably lies with the drive or the host computer.
- Has the drive been moved recently? Have any cables been disconnected and reconnected? Has the environment changed—unusually hot, cold, damp, or dry? Has there been dust or dirt near the drive. Have reasonable precautions against static been taken?

The problem could lie with the drive:

- Check the cables and connectors.
- Clean the tape heads with the cleaning cartridge.
- If the problem persists, check the environmental conditions against the specified limits. Perhaps move the drive to a more suitable site.

Routine maintenance

DDS drives require little care and maintenance. The two main activities are to:

- clean the heads regularly
- avoid condensation and temperature extremes.

Head Cleaning

Whenever the Cassette status LED (green) flashes, you should clean the drive heads with a cleaning cartridge.

Also, as routine maintenance, the drive heads should be cleaned after the first four hours of tape movement of a new cartridge and thereafter after every 25 hours of read/write operation.

Tape heads should be cleaned if the Media Caution signal is displayed on the front panel (the Cassette status LED flashes green) and continues to be displayed when you repeat the operation with a new tape. For more information about LED operation see Table 6, "Indicator LED operation," on page 22.

Use only a DDS DAT cleaning cartridge designed for DDS drives. The DDS cleaning cartridge contains the correct recognition holes to allow the drive to recognize that it is a cleaning cartridge.

Use the following steps to clean the heads using a cleaning cartridge:

- Step 1** Insert the cleaning cartridge into the drive. The drive automatically takes the cartridge, loads it, and cleans the heads.
- Step 2** After about 30 seconds, the drive ejects the cartridge.
If the Media Caution signal is still displayed after the cartridge is ejected, discard the cartridge, and repeat the cleaning operation with a new cleaning cartridge.
- Step 3** Take the cartridge out of the drive, and write the date on the cartridge label. This provides a record of how many times the cartridge has been used. A cleaning cartridge typically has a life of 50 cleaning cycles.

Temperature and Condensation

If the drive detects moisture (dew), the Drive status LED (yellow) flashes rapidly.

To avoid temperature or humidity problems, observe these guidelines:

- Place the drive in a position where the temperature is relatively stable, for example, away from open windows, fan heaters, and doors.
- Do not leave cartridges in severe temperature conditions, for example in a car standing in bright sunlight.
- Do not transfer data (reading from and writing to cartridges) when the temperature is changing by more than 10°C (50°F) per hour.
- After either the drive or the cartridge have been subjected to extreme temperature changes (>15°C, 59°F), do not use the drive for at least two hours to allow the temperature of the drive and cartridge to stabilize.

Verifying operation

The DDS-2 DAT drive subsystem can be verified by issuing OS level commands to read and write to the tape drive.

- Step 1** Write a file to tape by entering a `dd` command according to the following syntax:

```
dd if=input_file of=device_path bs=blocksize
```

where

```
dd
```

Copies the specified input file to the specified output.

```
if=input_file
```

Input file name; default is standard input.

```
of=output_file
```

Output file name; default is standard output.

```
bs=n
```

Block size. Set both input and output block size to the same size.

The following example writes an *input_file* called "test" to DDS-2 DAT drive 0.

```
dd if=test of=/dev/rmt/0m bs=512
```

- Step 2** Read the file from tape using a `dd` command according to the following syntax:

```
dd if=device_path of=output_file bs=blocksize
```

The following example reads the file "test" from tape and writes it to the files "testout" in the current directory.

```
dd if=/dev/rmt/0m/test of=testout bs=512
```

- Step 3** Compare the original file with the one read from the tape by entering a `cmp` command according to the following syntax:

```
cmp input_file output_file
```

where

```
cmp
```

Compares two files. Under default options, `cmp` makes no comment if the files are the same; if they differ, it will report the byte and line number at which the difference occurred.

```
input_file
```

The name of the original input file copied to tape in step 1.

output_file

The name of the file copied from tape in step 2.

The following example compares the file "test" with the file "testout" in the current directory.

```
cmp test testout
```

DAT drive and SCSI cable removal and replacement

6

This chapter contains the removal and replacement procedures and a FRU (Field Replacement Unit) list for the DDS-2 DAT drive and the DAT subsystem SCSI cables used in the Exemplar S-Class and X-Class Servers.

Precautions

Protect personnel and equipment when installing any Hewlett-Packard Company product by always taking proper precautions.

Electrostatic discharge (ESD)

Prepare an ESD safe work surface large enough to accommodate the DDS-2 DAT drive assembly.

Observe the electrostatic discharge procedures described in the "Electrostatic discharge protection" section on page xvii to prevent damage to the drive during installation.

Personal safety

Always insure that both the front panel and the power controller are turned off before removing or installing any components in the system.

Remove the front panel key after shutting the system down to prevent inadvertent power-on during installation.

DAT drive subsystem

The following section contains a block diagram of the DDS-2 DAT drive subsystem and a list of FRU part numbers.

Figure 13 illustrates the cable connections within the DDS-2 DAT drive subsystem. Table 7 contains descriptions of each part called out in Figure 13.

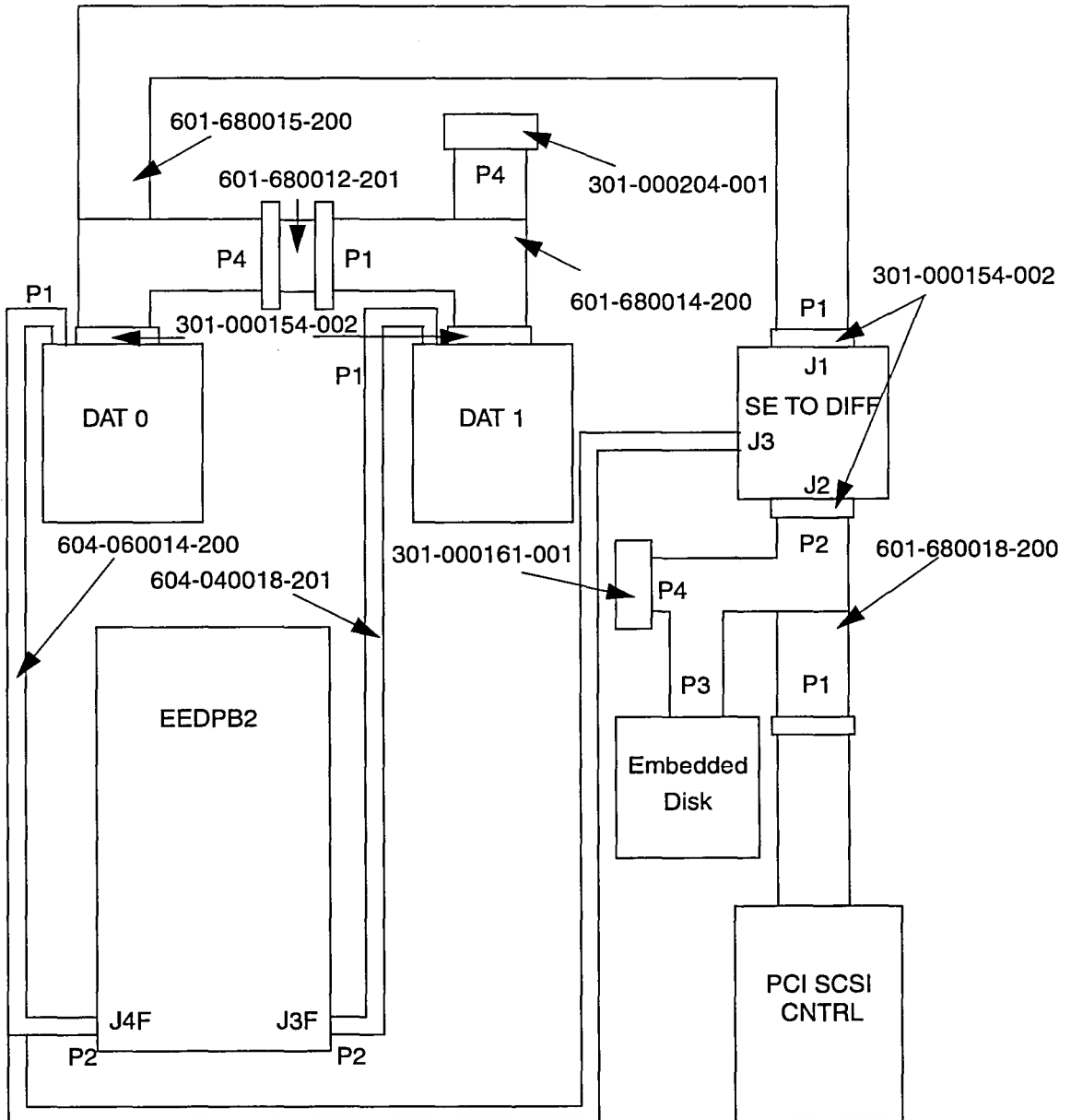

Figure 13 DDS-2 DAT drive cable block diagram

FRU (Field Replaceable Unit) part numbers

The following table contains the DDS-2 DAT drive FRU list.

Table 7 DDS-2 DAT drive FRU list

Part number	Description
550-000063-200	DAT TAPE ASSY, SCSI I/F, TSTD
200-001058-201	CONV, DC/DC 48V TO 5/12V 70W PEAK, W/DOT
201-000004-201	PC BD, SCSI SE TO DIFF CONVERTER
601-680015-200	CABLE ASSY, SCSI, BHD/EMBD PERIPH W/SUPP
601-680012-201	CABLE ASSY, SCSI, UA PERIPHERALS
601-680014-200	CABLE ASSY, SCSI, DIFF S/E, FRONT UA
601-680018-200	CABLE ASSY, SCSI, BHD/EMBD PERIPH W/SUPP
612-000019-002	CABLE ASSY, SCSI, SHIELDED W/BSHELL 13IN
604-060014-200	CABLE ASSY, DC PWR, EEDPB/SE CONV/UA
604-040018-201	CABLE ASSY, DC PWR,+12/+5 PERIPH UA FRNT
301-000204-001	CONN, 68 POS SCSI SE terminator, LO-PRO
301-000161-001	CONN, 68 POS SCSI DIFF TERMINATOR, LO-PRO
301-000154-002	CONN, 68POS TO 50POS F/F NO TERM

DDS-2 DAT drive removal and replacement

The following section provides instructions for the removal and replacement of a DDS-2 DAT drive (Part Number 550-000063-200) in the Exemplar S-Class and X-Class Servers.

Tools required

The following tools are required to complete the procedures in this chapter:

- Phillips screwdriver
- Personal grounding system
- Static dissipating mat

Overview of removal and replacement

Replacing a DDS-2 DAT drive involves some minor disassembly of system assemblies. The following steps summarize the replacement process.

This list is intended for summary purposes only; detailed removal and replacement instructions are presented in the "Removing the DDS-2 DAT drive" section on page 35 and the "Installing the new DDS-2 DAT drive" section on page 38.

- Step 1** Shut down the system.
- Step 2** Remove the LCD control panel.
- Step 3** Remove the DDS-2 DAT drive cage assembly.
- Step 4** Disconnect the SCSI cable from the rear of the drive.
- Step 5** Disconnect the power cable from the rear of the drive.
- Step 6** Remove the DDS-2 DAT drive from the drive cage.
- Step 7** Transfer the 68-pin to 50-pin adapter to the new drive.
- Step 8** Install the new DDS-2 DAT drive into the drive cage.
- Step 9** Attach the SCSI cable to the rear of the drive.
- Step 10** Attach the power cable to the rear of the drive.
- Step 11** Install the DDS-2 DAT drive cage assembly into the bay.
- Step 12** Reinstall the LCD control panel.
- Step 13** Reboot the system and verify DDS-2 DAT drive operation.

Removing the DDS-2 DAT drive

To remove the DDS-2 DAT drive, perform the following steps:

- Step 1** Shut down the system with the `/etc/shutdown` command.

The *time* argument can be used to schedule a timed shutdown or the keyword "now" can be used to shut down the system immediately.

```
/etc/shutdown -h now
```

- Step 2** Remove power to the system by turning the keyswitch on the operator panel to the OFF position.

Caution

Do not attempt to remove the DDS-2 DAT drive before removing power to the cabinet. Failure to remove power before removing the DDS-2 DAT drive damages electronic components on the drive assembly.

- Step 3** Remove the LCD control panel by removing four screws securing the panel. Carefully place the LCD control panel on top of the chassis.
- Step 4** Remove the two screws securing the DDS-2 DAT drive cage assembly.

- Step 5** Slide the DDS-2 DAT drive cage assembly from the DAT drive bay. See Figure 14.

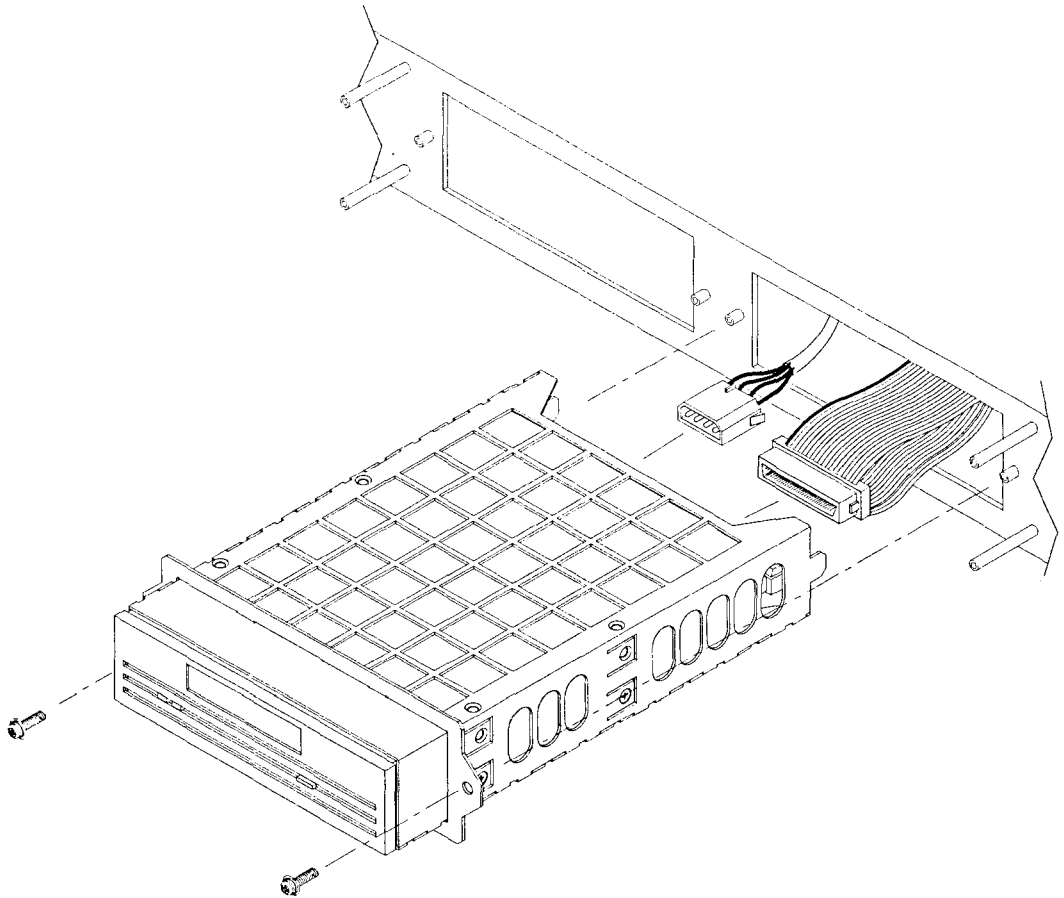

10EXS041
12/10/98

Figure 14 Removing the DDS-2 DAT drive from the drive bay

- Step 6** Disconnect the SCSI cable from the rear of the DDS-2 DAT drive cage assembly.
- Step 7** Disconnect the power cable from the rear of the DDS-2 DAT drive cage assembly.

- Step 8** Remove the DDS-2 DAT drive from the drive cage by removing four screws (two on either side) and sliding the DDS-2 DAT drive out of the drive cage. See Figure 15.

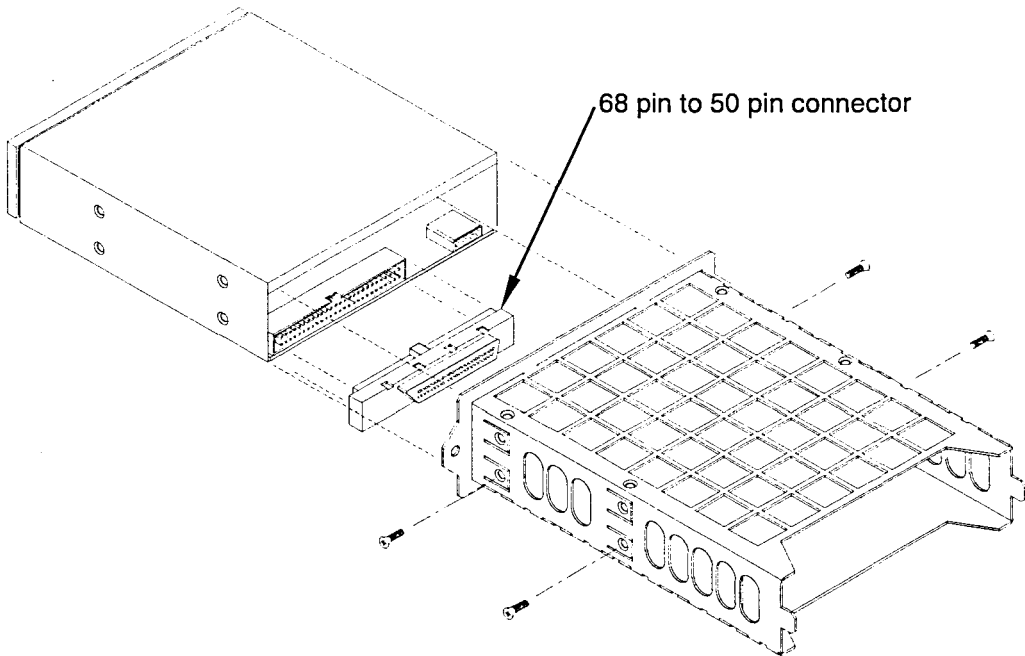

IOEXS043
12/11/96

Figure 15 Removing the drive cage

- Step 9** Remove the 68-pin to 50-pin adapter from the SCSI connector of the DDS-2 DAT drive. Retain the adapter for later use. See Figure 15.

Installing the new DDS-2 DAT drive

To install the DDS-2 DAT drive, use the following procedure:

- Step 1** Install the 68-pin to 50-pin adapter taken from the old drive onto the SCSI connector of the replacement DDS-2 DAT drive. See Figure 15.
- Step 2** Verify that the jumpers are set correctly. See the "Drive jumpers" section on page 4, for jumper setting definitions.
- Step 3** Insert the new DDS-2 DAT drive into the drive cage and secure it with four screws. See Figure 15.
- Step 4** Attach the SCSI cable to the back of the DDS-2 DAT drive. See Figure 14.
- Step 5** Attach the power cable to the back of the DDS-2 DAT drive. See Figure 14.
- Step 6** Slide the DDS-2 DAT drive cage assembly into the drive bay. The SCSI cable and power supply cable should fold up and over the top of the drive and lay flat.
- Step 7** Mate the tabs on each side of the DDS-2 DAT drive cage assembly with the corresponding slots in the back wall of the drive bay.
- Step 8** Secure the DDS-2 DAT drive cage assembly with two screws.
- Step 9** Reinstall the LCD control panel using four screws.

Cable removal and replacement

The following section provides instructions for the removal and replacement of cabling for the DDS-2 DAT drives in the Exemplar S-Class and X-Class Servers.

Note

Observe routing before removing any factory installed cable. Dress and route replacement cables in the original manner.

DAT drive 0 SCSI cable

This section provides instructions for the removal and replacement of the DAT drive 0 SCSI cable (Part Number 601-060015-200). See Figure 13, "DDS-2 DAT drive cable block diagram," on page 32.

Tools required

The following tools are required to complete the procedures in this chapter.

- Phillips screwdriver
- Personal grounding system
- Static dissipating mat

Overview of removal and replacement

Replacing any DAT drive cabling involves some minor disassembly of system assemblies. The following list provides a summary of the steps involved in the replacement process.

This list is intended for summary purposes only; detailed installation instructions are presented in the "DAT drive 0 SCSI cable replacement procedure" section on page 40.

- Step 1** Shut down the system.
- Step 2** Remove the front skin, left side skin, filter, and Electromagnetic Interference (EMI) panels.
- Step 3** Remove the LCD control panel.
- Step 4** Remove the DDS-2 DAT drive 0 cage assembly.
- Step 5** Remove the DDS-2 DAT drive 1 cage assembly or DDS-2 DAT drive blank panel if installed.
- Step 6** Remove the cable run plate.
- Step 7** Remove the cable.

- Step 8** Dress the new cable.
- Step 9** Replace the cable.
- Step 10** Replace the cable run plate.
- Step 11** Reinstall the DDS-2 DAT drive 0 cage assembly into the bay.
- Step 12** Reinstall the DDS-2 DAT drive 1 cage assembly or DAT drive blank panel into the bay.
- Step 13** Reinstall the LCD control panel.
- Step 14** Reboot the system and verify DDS-2 DAT drive operation.
- Step 15** Reinstall EMI panels, filter, front skin, and left side skin.

DAT drive 0 SCSI cable replacement procedure

The DAT drive 0 SCSI cable (Part Number 601-680015-200) runs from the DAT drive bay interconnect, to the SCSI connector at the rear of DDS-2 DAT drive 0, to J1 of the SCSI SE TO DIFF converter as shown in Figure 13, "DDS-2 DAT drive cable block diagram," on page 32.

- Step 1** Shut down the system with the `/etc/shutdown` command.
The *time* argument can be used to schedule a timed shutdown or the keyword "now" can be used to shut down the system immediately.
`/etc/shutdown -h now`
- Step 2** Remove power to the system by turning the keyswitch on the operator panel to the OFF position.

Caution

Do not attempt to remove the DDS-2 DAT drive before removing power to the cabinet. Failure to remove power before removing the DDS-2 DAT drive damages electronic components on the drive assembly.

- Step 3** Remove the front cabinet skin by pulling from the top and bottom of the skin until it pops out as shown in Figure 16.
- Step 4** Remove the filter from the front of the chassis as shown in Figure 16.
- Step 5** Remove the front EMI panel by unfastening the screws securing the panel. See Figure 16.

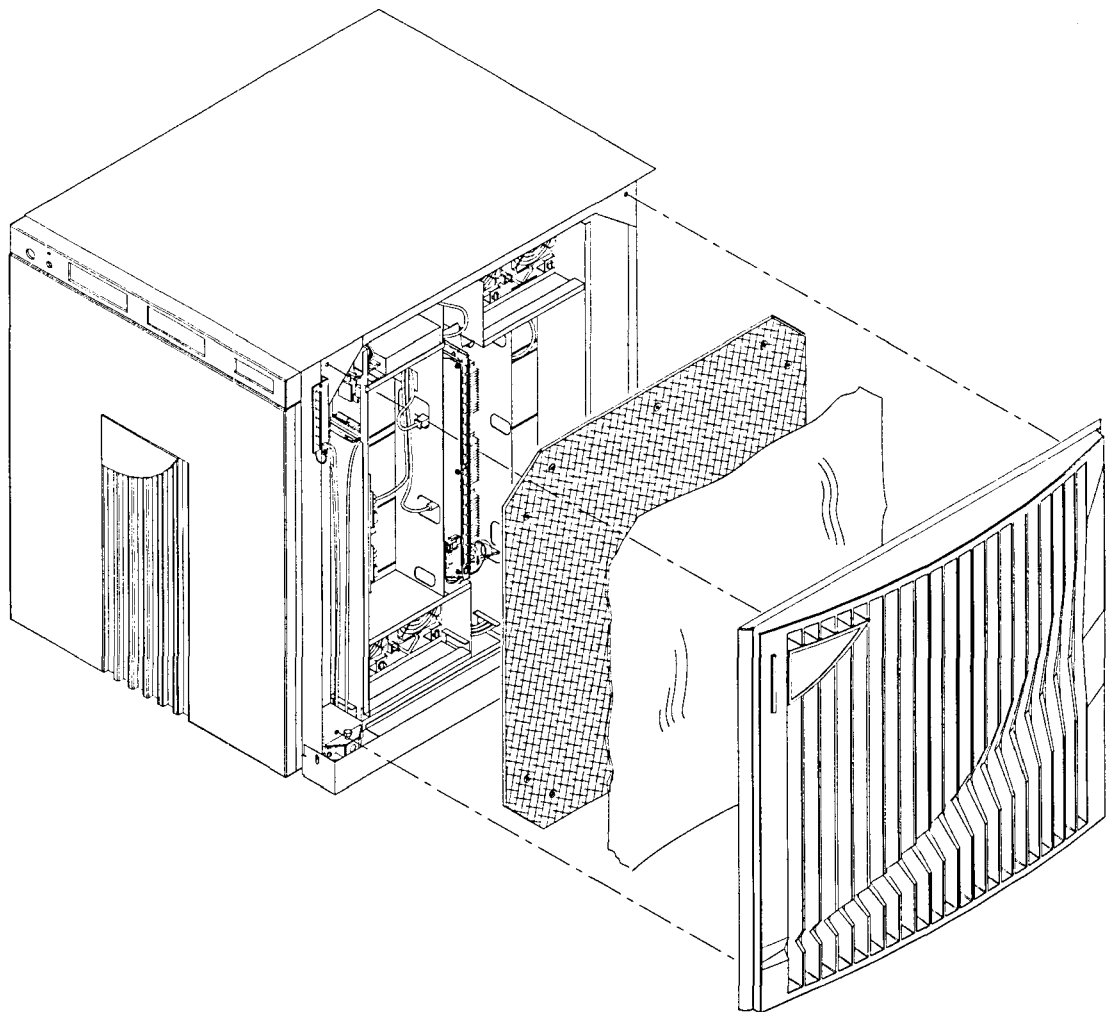

EXSM056
12/17/96

Figure 16 Removing front skin, filter, and EMI panel

- Step 6** Disconnect P1 of the DAT drive 0 SCSI cable (Part Number 601-680015-200) connector from J1 of the SCSI SE TO DIFF converter board (Part Number 201-000004-201).

Note

Do not remove the 68-pin to 58-pin adapter (Part Number 301-000154-002) from J1 of the SCSI SE TO DIFF converter board.

- Step 7** Remove the left side cabinet skin by pulling from the top and bottom of the skin until it pops out as shown in Figure 17.
- Step 8** Remove the EMI panel by unfastening the screws securing the panel. See Figure 17.

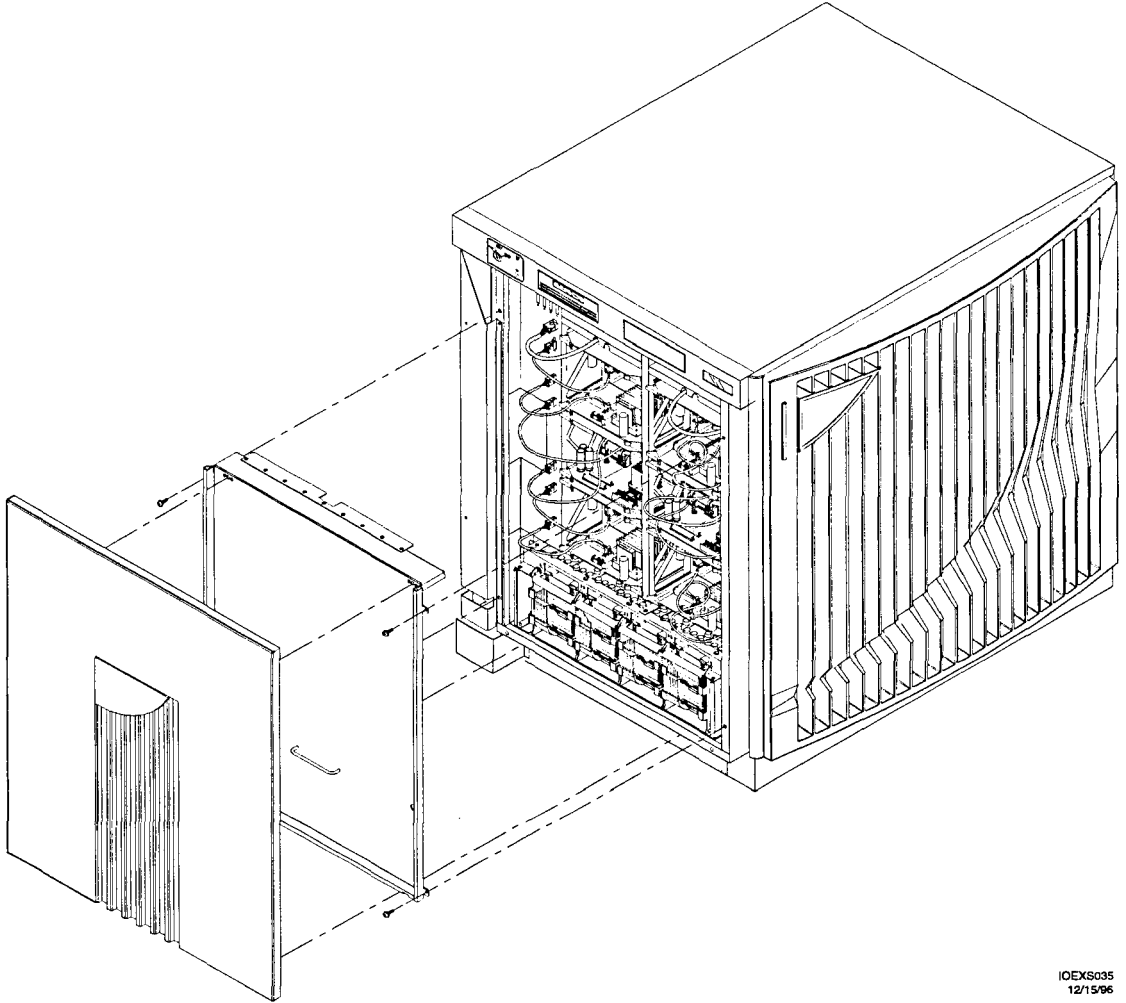

Figure 17 Removing side skin and EMI panel

- Step 9** Remove the LCD control panel by removing four screws securing the panel. Carefully place the LCD control panel on top of the chassis.

- Step 10** Remove the two screws securing the DDS-2 DAT drive 0 cage assembly. See Figure 18.
- Step 11** Slide the DDS-2 DAT drive cage assembly from the DDS-2 DAT drive 0 bay. See Figure 18.

Note

Figure 18, showing DDS-2 DAT drive 1, is used here as a general reference. The operation in step 10 should be performed on the DDS-2 DAT drive 0 position.

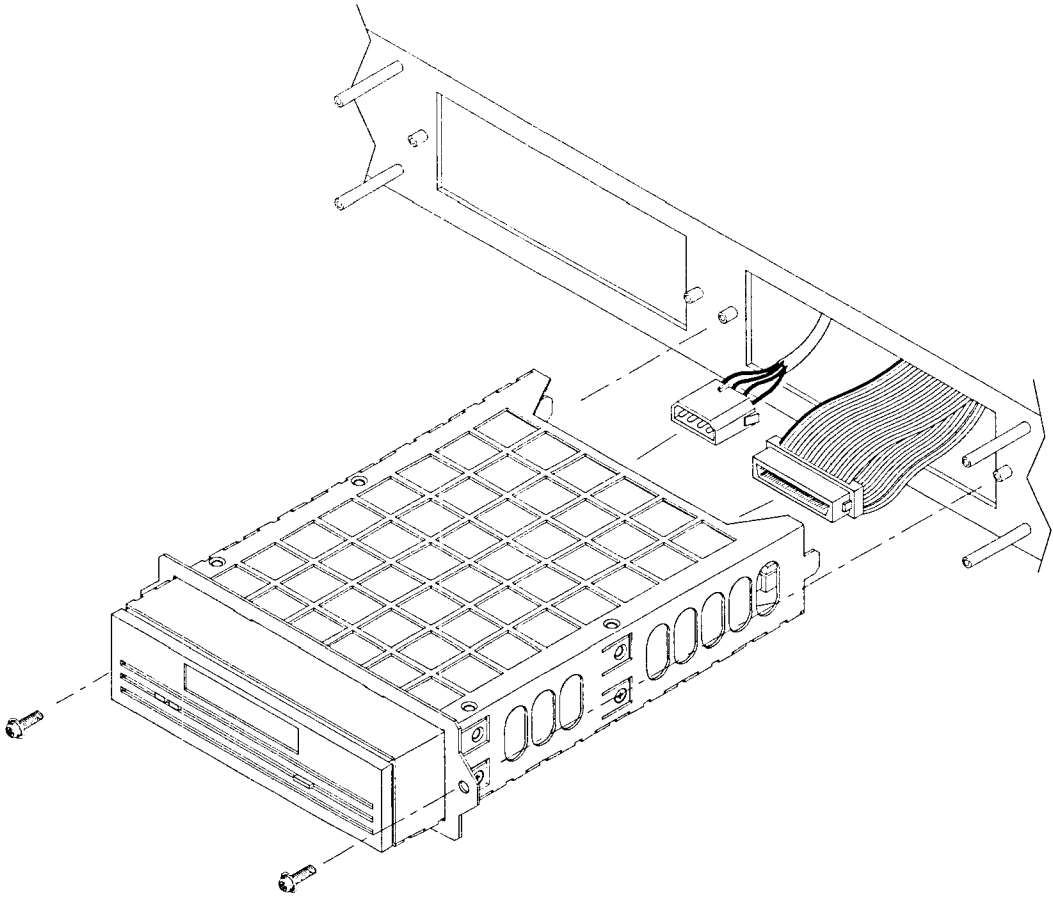

IOEXS041
12/10/96

Figure 18 Removing the DDS-2 DAT drive from the drive bay

- Step 12** Disconnect the SCSI cable from the rear of the DDS-2 DAT drive 0 cage assembly.

Note

Do not remove the 68-pin to 58-pin adapter (Part Number 301-000154-002) from the SCSI connector of the DDS-2 DAT drive.

- Step 13** Disconnect the power cable from the rear of the DDS-2 DAT drive 0 cage assembly.
- Step 14** Place the DDS-2 DAT drive on a level work surface that contains a grounded static dissipating mat.
- Step 15** Repeat steps 10 through 14 for DDS-2 DAT drive 1 if installed. Otherwise remove the DAT drive blank panel from the chassis by removing the two screws that secure the panel as shown in Figure 19.

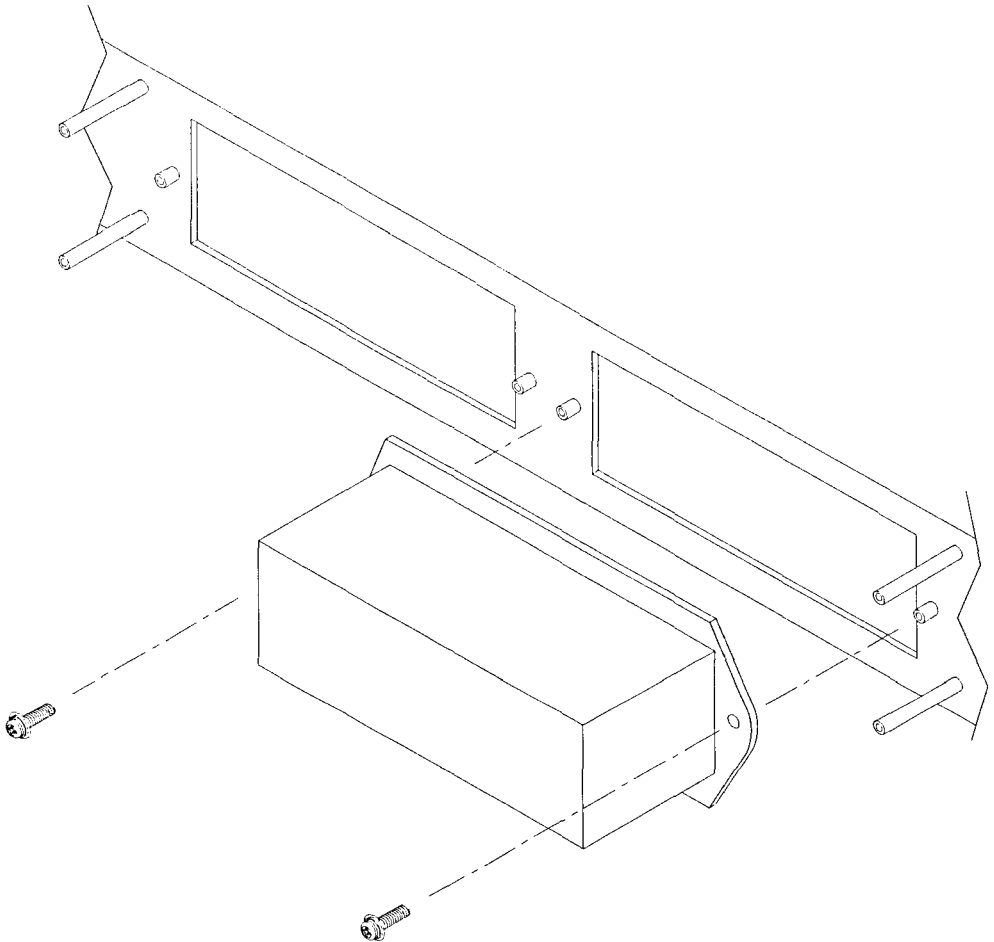
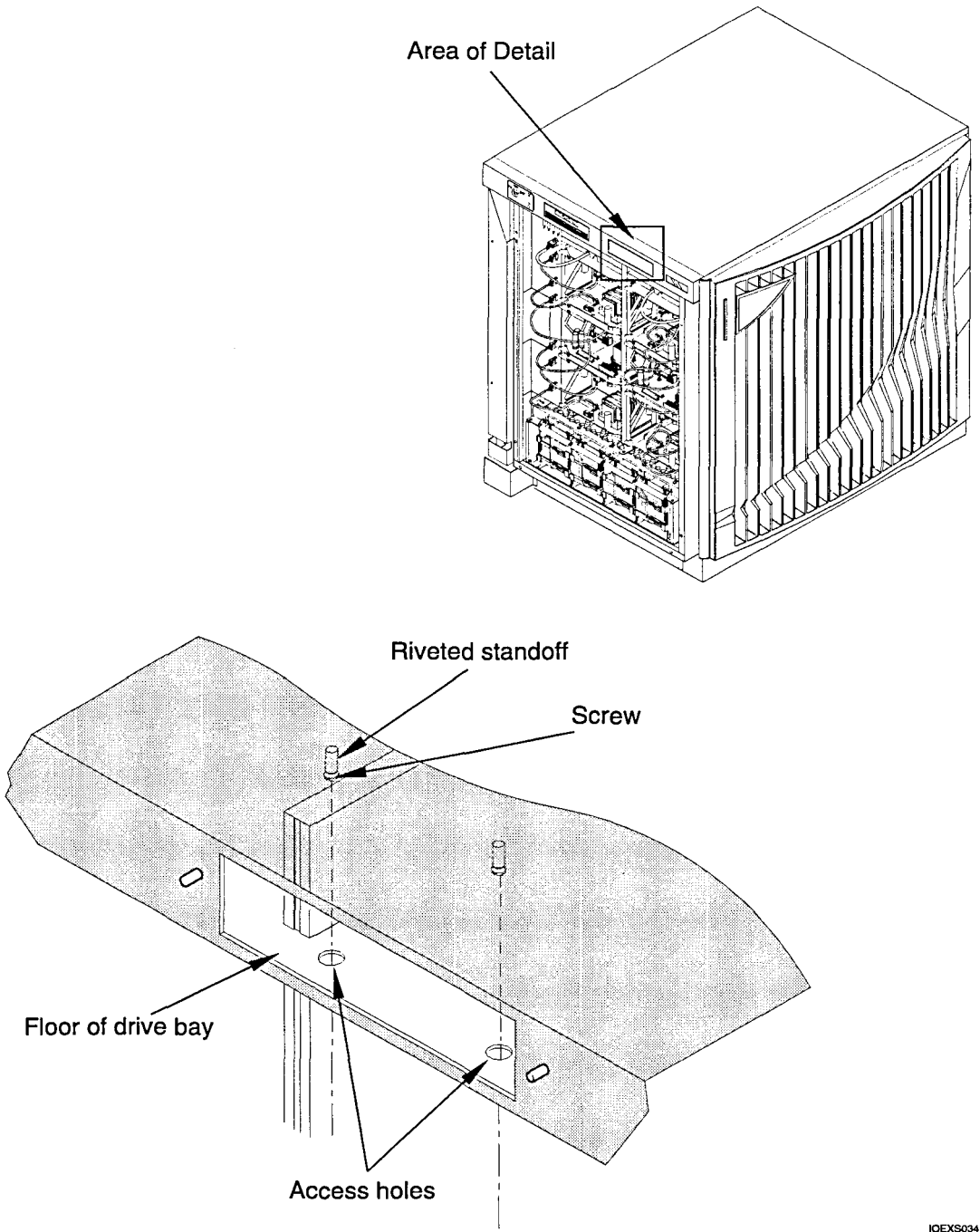

Figure 19 Removing the DDS-2 DAT blank panel

- Step 16** Remove two screws to disconnect P4 of the DAT drive 0 SCSI cable (Part Number 601-680015-200) from the drive 0 bay bulkhead connector.

Step 17 Remove the cable run plate by loosening the two screws securing it to the top of the DAT drive bay. Two screwdriver access holes are situated in the floor of the DAT drive bay. See Figure 20.

Slide the plate toward the rear of the bay and down to release it.



IOEXS034
12/11/06

Figure 20 DAT drive bay

- Step 18** Remove the plate and SCSI cable from the drive bay. Carefully feed the SCSI cable through the chassis as you extract it.
- Step 19** Using the old cable as a model carefully fold the new SCSI cable (Part Number 601-680015-200) and place it on the cable run plate.
- Step 20** Place the new SCSI cable and cable run plate onto the floor of the DAT drive bay so that the power cable lies on the cable run plate.
- Step 21** Install the cable run plate in the DAT drive bay by pressing it up onto both screws in the top of the bay and sliding the plate toward the front of the bay.
- Step 22** Feed the new SCSI cable (Part Number 601-680015-200) through the DAT drive bulkheads and attach P1 of the cable to the 68-pin to 58-pin adapter in J1 of the SCSI SE TO DIFF converter board (Part Number 201-000004-201).
- Step 23** Attach the SCSI cable (Part Number 601-680015-200) to the 68-pin to 58-pin adapter in the SCSI connector of the DDS-2 DAT drive. See Figure 18.
- Step 24** Attach the power 0 cable to the back of the DDS-2 DAT drive. See Figure 18.
- Step 25** Slide the DDS-2 DAT drive cage assembly into the drive bay. The SCSI cable and power supply cable should fold up and over the top of the drive and lay flat.
- Step 26** Mate the tabs on each side of the DDS-2 DAT drive cage assembly with the corresponding slots in the back wall of the drive bay.
- Step 27** Secure the DDS-2 DAT drive cage assembly with two screws.
- Step 28** Repeat steps 23 through 27 for DDS-2 DAT drive 1 if installed, otherwise, replace the DAT drive blank panel by using two screws to secure the panel as shown in Figure 19.
- Step 29** Reinstall the LCD control panel using four screws.
- Step 30** Reinstall the EMI panels and side skins.

DAT drive 0 to drive 1 SCSI jumper cable

This section provides instructions for the removal and replacement of the DAT drive 0 to drive 1 SCSI jumper cable (Part Number 601-060012-201).

Tools required

The following tools are required to complete the procedures in this chapter.

- Phillips screwdriver
- Personal grounding system
- Static dissipating mat

Overview of removal and replacement

Replacing any DAT drive cabling involves some minor disassembly of system assemblies. The following list provides a summary of the steps involved in the replacement process.

This list is intended for summary purposes only; detailed installation instructions are presented in the "DAT drive 0 SCSI cable replacement procedure" section on page 40.

- Step 1** Shut down the system.
- Step 2** Remove the LCD control panel.
- Step 3** Remove the DDS-2 DAT drive 0 cage assembly.
- Step 4** Remove the DDS-2 DAT drive 1 cage assembly or DAT drive blank panel if installed.
- Step 5** Remove the SCSI jumper cable.
- Step 6** Replace the SCSI jumper cable.
- Step 7** Reinstall the DDS-2 DAT drive 0 cage assembly into the bay.
- Step 8** Reinstall the DDS-2 DAT drive 1 cage assembly or DAT drive blank panel into the bay.
- Step 9** Reinstall the control panel.
- Step 10** Reboot the system and verify DDS-2 DAT drive operation.

DAT 0 to drive 1 SCSI jumper cable replacement procedure

The DAT 0 to drive 1 SCSI jumper cable runs between the two DAT drive bays and mounts to a connector in each bay as shown in Figure 13, "DDS-2 DAT drive cable block diagram," on page 32.

- Step 1** Shut down the system with the `/etc/shutdown` command.

The *time* argument can be used to schedule a timed shutdown or the keyword "now" can be used to shut down the system immediately.

```
/etc/shutdown -h now
```

- Step 2** Remove power to the system by turning the keyswitch on the operator panel to the OFF position.

Caution

Do not attempt to remove the DDS-2 DAT drive before removing power to the cabinet. Failure to remove power before removing the DDS-2 DAT drive damages electronic components on the drive assembly.

- Step 3** Remove the front cabinet skin by pulling from the top and bottom of the skin until it pops out as shown in Figure 21.
- Step 4** Remove the filter from the front of the chassis as shown in Figure 21.
- Step 5** Remove the front EMI panel by unfastening the screws securing the panel. See Figure 21.

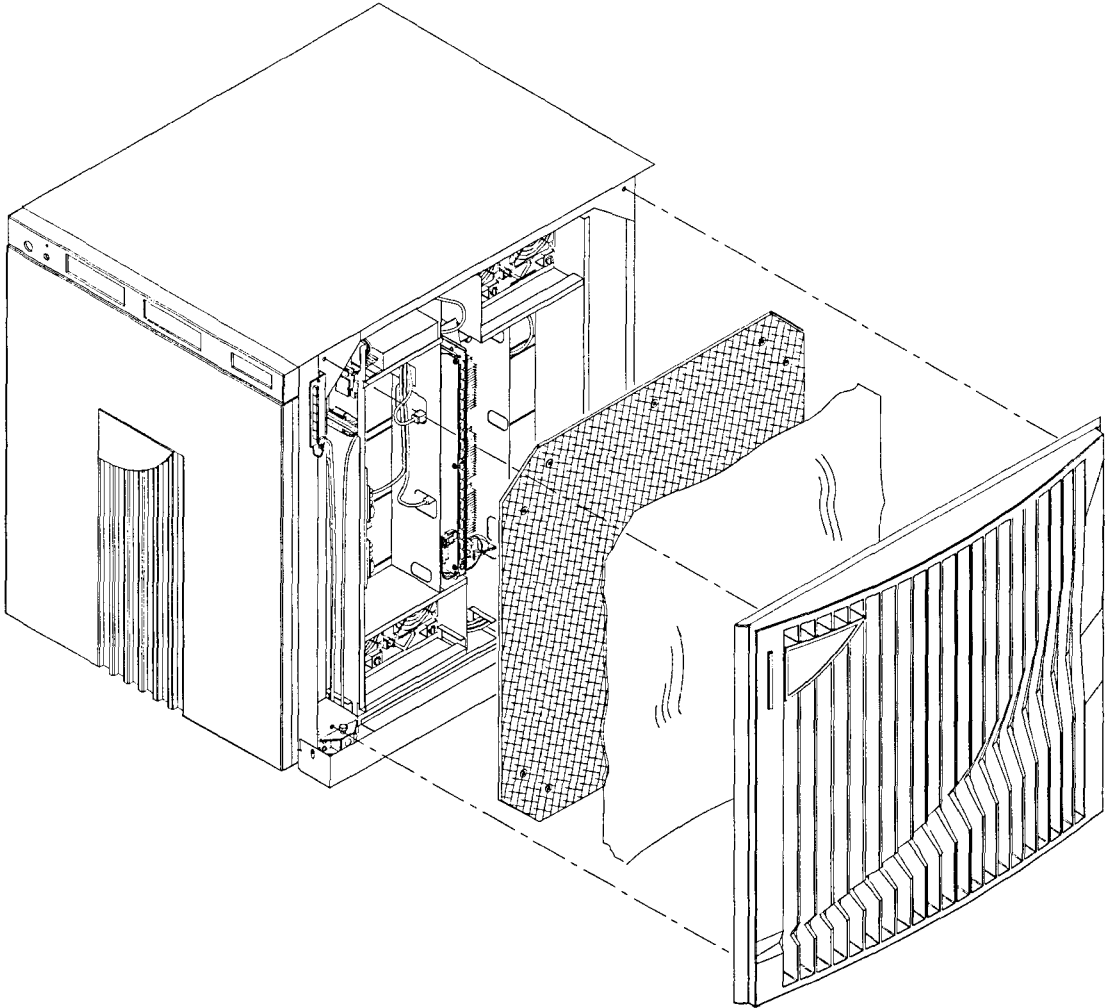

EXSM056
12/17/96

Figure 21 Removing front skin and EMI panel

- Step 6** Disconnect P1 of the DAT drive 0 SCSI cable (Part Number 601-680015-200) from J1 of the SCSI SE TO DIFF converter board (Part Number 201-000004-201).

Note

Do not remove the 68-pin to 58-pin adapter (Part Number 301-000154-002) from J1 of the SCSI SE TO DIFF converter board

- Step 7** Remove the LCD control panel by removing four screws securing the panel. Carefully place the LCD control panel on top of the chassis.
- Step 8** Remove the two screws securing the DDS-2 DAT drive 0 cage assembly. See Figure 22.
- Step 9** Slide the DDS-2 DAT drive 0 cage assembly from the DAT drive bay. See Figure 22.

Note

Do not remove the 68-pin to 58-pin adapter (Part Number 301-000154-002) from the SCSI connector of the DDS-2 DAT drive

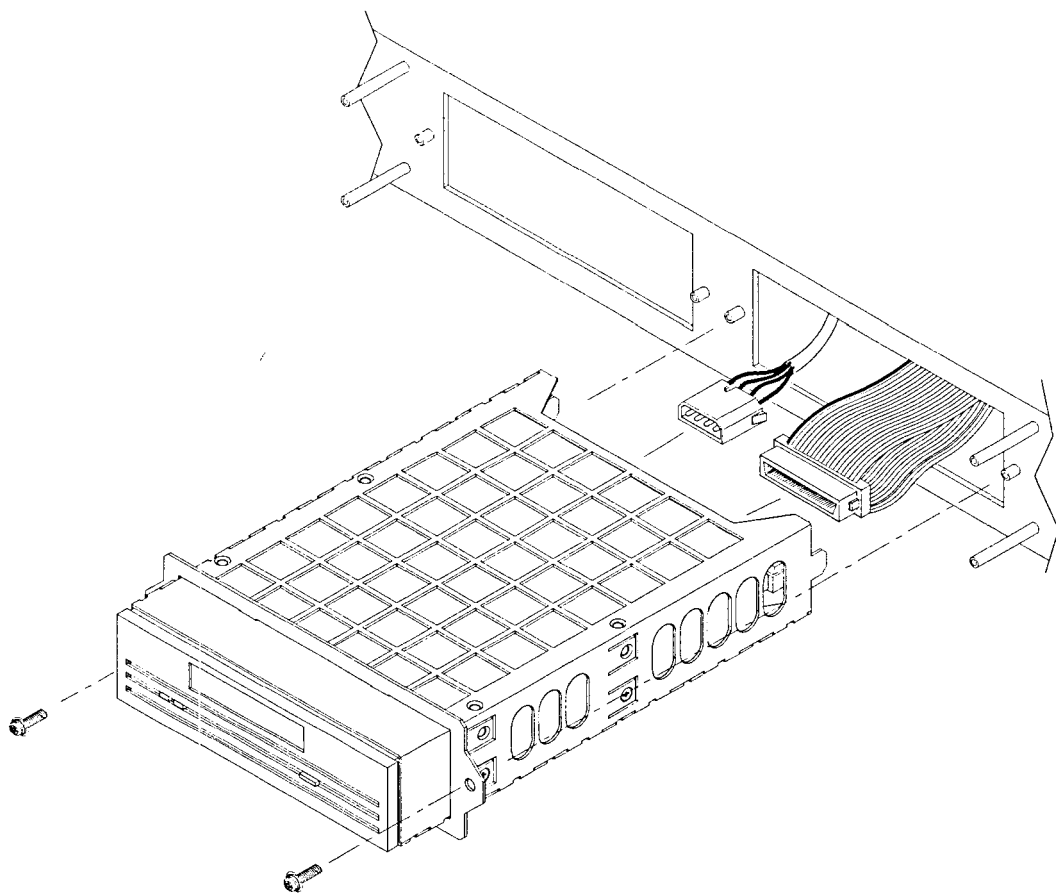

IOEXS041
12/10/96

Figure 22 Removing the DDS-2 DAT drive from the drive bay

- Step 10** Disconnect the SCSI cable from the rear of the DDS-2 DAT drive 0 cage assembly. See Figure 22.

- Step 11** Disconnect the power cable from the rear of the DDS-2 DAT drive cage assembly. See Figure 22.
- Step 12** Place the DDS-2 DAT drive on a level work surface that contains a grounded static dissipating mat.
- Step 13** Repeat steps 8 through 12 for DDS-2 DAT drive 1 if installed, otherwise, remove the DAT drive blank panel from the chassis by removing the two screws that secure the panel as shown in Figure 23.

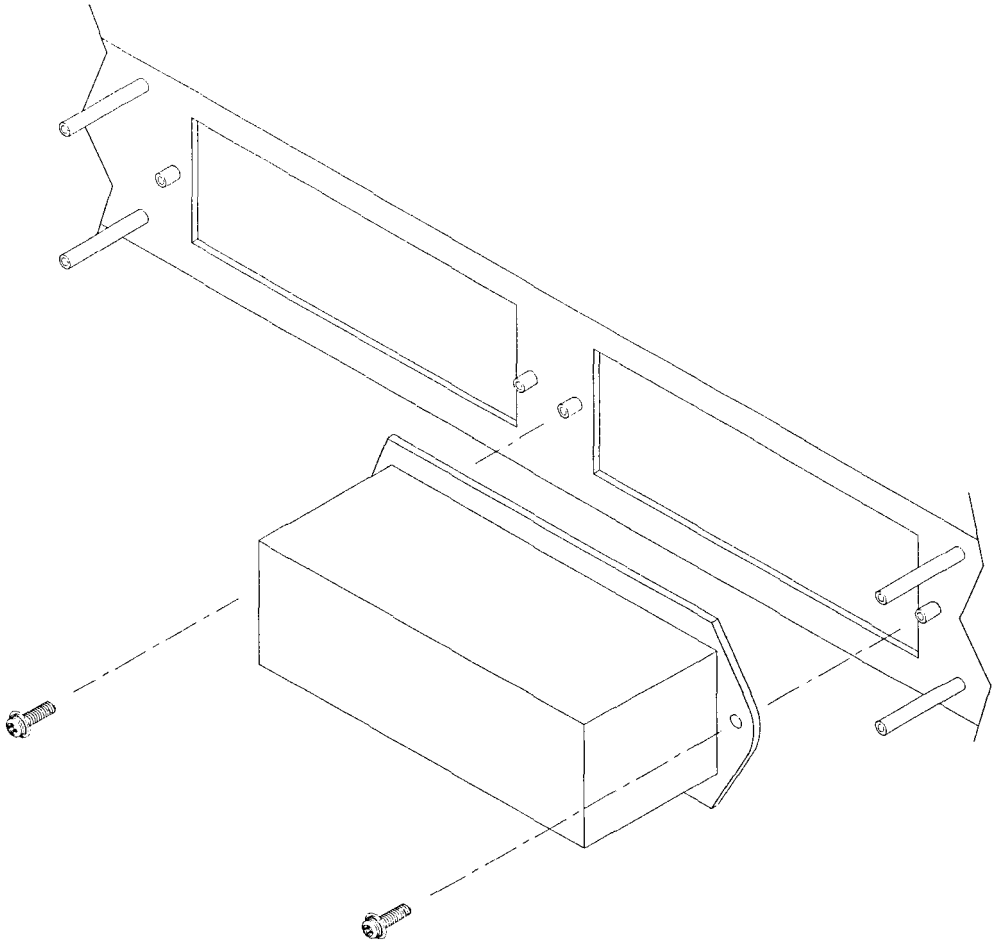

Figure 23 Removing the DAT drive blank panel

- Step 14** Remove two screws on each connector to disconnect the DAT drive SCSI jumper cable (Part Number 601-680012-201) from the drive 0 and drive 1 bay bulkhead.

- Step 15** Replace the DAT drive SCSI jumper cable (Part Number 601-680012-201) and secure with two screws at each connector.
- Step 16** Attach the SCSI cable to the back of the DDS-2 DAT drive 0. See Figure 22.
- Step 17** Attach the power cable to the back of the DDS-2 DAT drive 0. See Figure 22.
- Step 18** Slide the DDS-2 DAT drive 0 cage assembly into the drive bay. The SCSI cable and power supply cable should fold up and over the top of the drive and lay flat.
- Step 19** Mate the tabs on each side of the DDS-2 DAT drive cage assembly with the corresponding slots in the back wall of the drive bay.
- Step 20** Secure the DDS-2 DAT drive cage assembly with two screws.
- Step 21** Repeat steps 16 through 20 for DDS-2 DAT drive 1 if installed, otherwise, replace the DAT drive blank panel by using two screws to secure the panel as shown in Figure 23.
- Step 22** Reinstall the LCD control panel using four screws.

DAT drive 1 SCSI cable

This section provides instructions for the removal and replacement of the DAT drive 0 SCSI jumper cable (Part Number 601-060014-200).

Tools required

The following tools are required to complete the procedures in this chapter.

- Phillips screwdriver
- Personal grounding system
- Static dissipating mat

Overview of removal and replacement

Replacing any DDS-2 DAT drive cabling involves some minor disassembly of system assemblies. The following list provides a summary of the steps involved in the replacement process.

This list is intended for summary purposes only; detailed installation instructions are presented in the "DAT drive 1 SCSI cable replacement procedure" section on page 55.

- Step 1** Shut down the system.
- Step 2** Remove the left side skin and Electromagnetic Interference (EMI) panels.
- Step 3** Remove the LCD control panel.
- Step 4** Remove the DDS-2 DAT drive 1 cage assembly.
- Step 5** Remove the cable run plate.
- Step 6** Remove the cable.
- Step 7** Dress the new cable.
- Step 8** Replace the cable.
- Step 9** Replace the cable run plate.
- Step 10** Reinstall the DDS-2 DAT drive 1 cage assembly into the bay.
- Step 11** Reinstall the LCD control panel.
- Step 12** Reboot the system and verify DAT drive operation.
- Step 13** Reinstall EMI panel and left side skin.

DAT drive 1 SCSI cable replacement procedure

The DAT drive 1 SCSI cable runs from the DAT drive bay interconnect to the SCSI connector at the rear of DDS DAT drive 1, to the right DAT drive bay bulkhead, and terminates there as shown in Figure 13, "DDS-2 DAT drive cable block diagram," on page 32.

Step 1 Shut down the system with the `/etc/shutdown` command.

The *time* argument can be used to schedule a timed shutdown or the keyword "now" can be used to shut down the system immediately.

```
/etc/shutdown -h now
```

Step 2 Remove power to the system by turning the keyswitch on the operator panel to the OFF position.

Caution

Do not attempt to remove the DAT drive before removing power to the cabinet. Failure to remove power before removing the DAT drive damages electronic components on the drive assembly.

- Step 3** Remove the front cabinet skin by pulling from the top and bottom of the skin until it pops out as shown in Figure 24.
- Step 4** Remove the filter from the front of the chassis as shown in Figure 24.
- Step 5** Remove the front EMI panel by unfastening the screws securing the panel. See Figure 24.

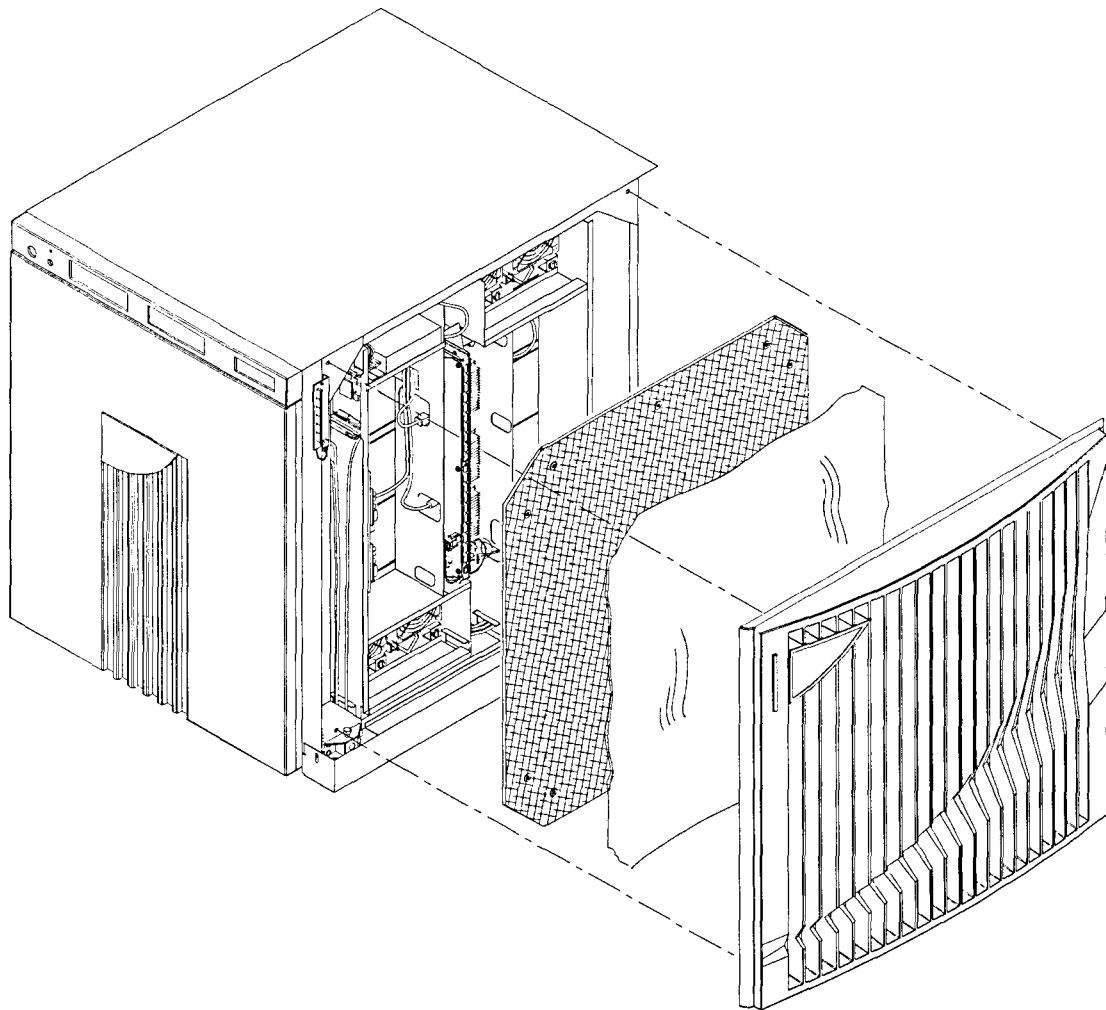

EXSM056
12/17/96

Figure 24 Removing front skin and EMI panel

- Step 6** Remove the left side cabinet skin by pulling from the top and bottom of the skin until it pops out as shown in Figure 25.
- Step 7** Remove the EMI panel by unfastening the screws securing the panel. See Figure 25.

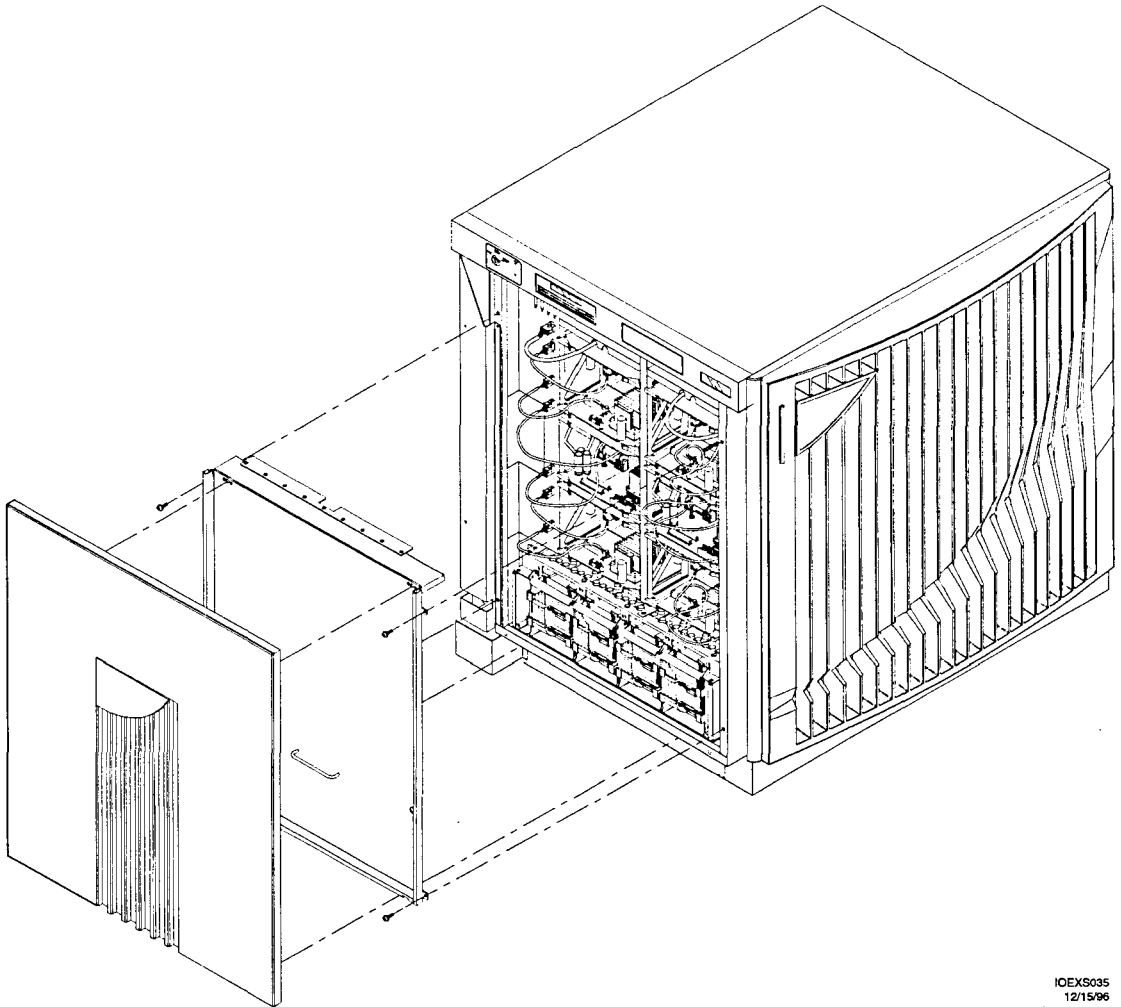

IOEX5035
12/15/96

Figure 25 Removing side skin and EMI panel

- Step 8** Remove the LCD control panel by removing four screws securing the panel. Carefully place the LCD control panel on top of the chassis.
- Step 9** Remove the two screws securing the DDS-2 DAT drive 1 cage assembly.

Step 10 Slide the DDS-2 DAT drive 1 cage assembly from the DAT drive bay. See Figure 26.

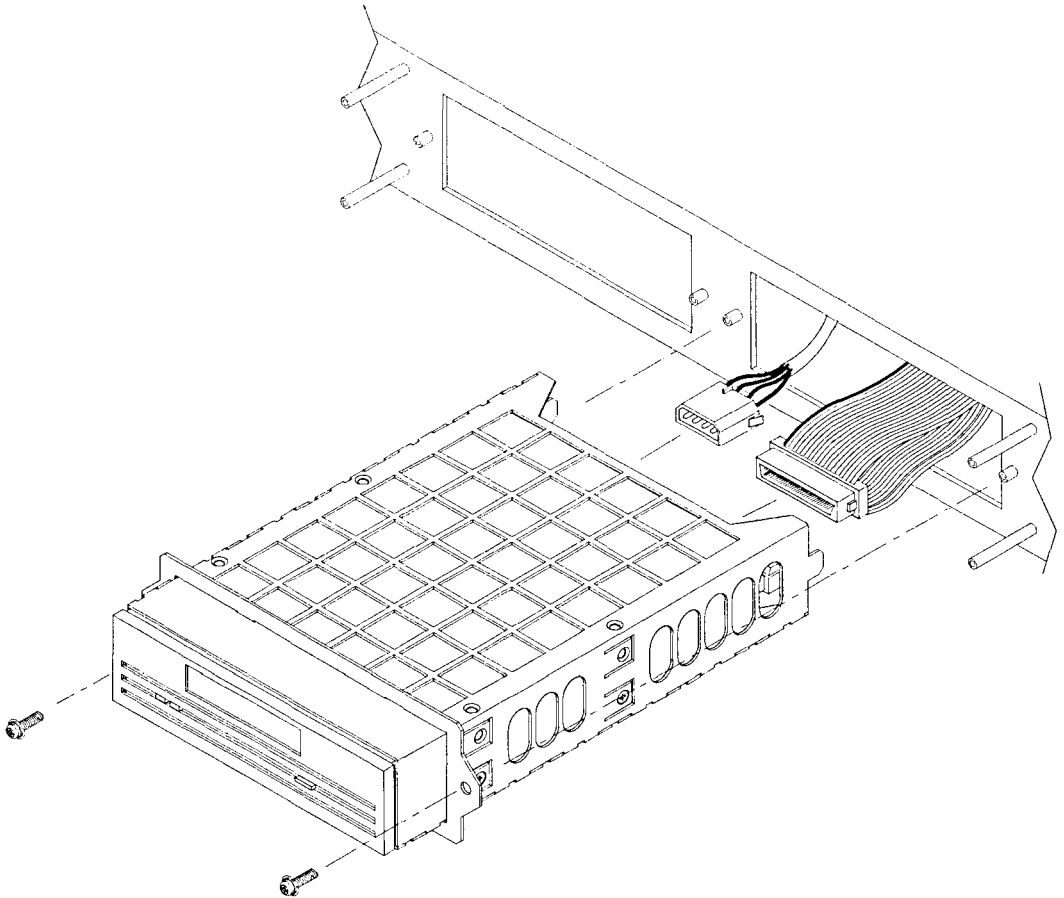

IOEXS041
12/10/96

Figure 26 Removing the DAT drive from the drive bay

- Step 11** Disconnect the SCSI cable from the rear of the DDS-2 DAT drive cage assembly.
- Step 12** Disconnect the power cable from the rear of the DDS-2 DAT drive cage assembly.
- Step 13** Place the DDS-2 DAT drive on a level work surface that contains a grounded static dissipating mat.
- Step 14** Disconnect P1 of the DAT drive 1 SCSI cable from the drive 1 bay left bulkhead connector by removing two screws.
- Step 15** Disconnect P4 of the DAT drive 1 SCSI cable from the drive 1 bay right bulkhead connector by removing two screws.

- Step 16** Remove the cable run plate by loosening the two screws securing it to the top of the DAT drive bay. Two screwdriver access holes are situated in the floor of the DAT drive bay. See Figure 27.
- Slide the plate toward the rear of the bay and down to release it.

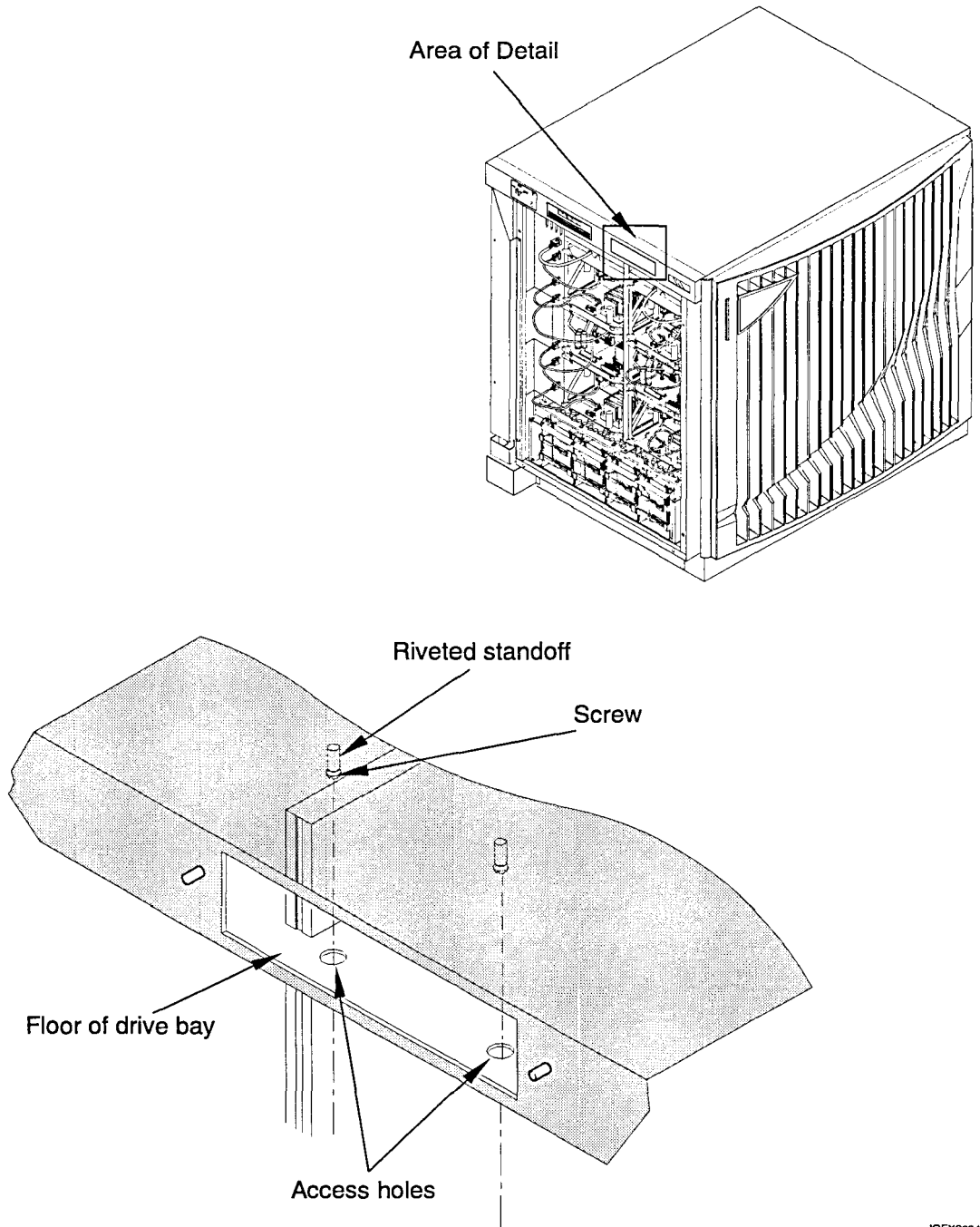

IOEXS034
12/11/96

Figure 27 DAT drive bay

- Step 17** Remove the plate and SCSI cable from the drive bay.
- Step 18** Using the old cable as a model, carefully fold the new SCSI cable (Part Number 601-680014-200) and place it on the cable run plate.
- Step 19** Place the new SCSI cable and cable run plate into the DAT drive bay so that the power cable lies on the cable run plate.
- Step 20** Install the cable run plate in the DAT drive bay by pressing it up onto both screws in the top of the bay and sliding the plate toward the front of the bay.
- Step 21** Attach P1 of the new DAT drive 1 SCSI cable to the drive 1 bay left bulkhead connector using two screws.
- Step 22** Attach P4 of the new DAT drive 1 SCSI cable to the drive 1 bay right bulkhead connector using two screws.
- Step 23** Attach the SCSI cable to the back of the DDS-2 DAT drive 1. See Figure 26.
- Step 24** Attach the power cable to the back of the DDS-2 DAT drive 1. See Figure 26.
- Step 25** Slide the DDS-2 DAT drive 1 cage assembly into the drive bay. The SCSI cable and power supply cable should fold up and over the top of the drive and lay flat.
- Step 26** Mate the tabs on each side of the DDS-2 DAT drive cage assembly with the corresponding slots in the back wall of the drive bay.
- Step 27** Secure the DDS-2 DAT drive 1 cage assembly with two screws.
- Step 28** Reinstall the LCD control panel using four screws.
- Step 29** Reinstall the EMI panel and side skin.

Replacing the bulkhead to embedded drive SCSI cable

This section provides instructions for the removal and replacement of the "bulkhead to embedded drive SCSI cable" (Part Number 601-680018-200).

Note

Observe routing before removing any factory installed cable. Dress and route replacement cables in the original manner.

Tools required

The following tools are required to complete the procedures in this chapter.

- Phillips screwdriver
- Personal grounding system
- Static dissipating mat

Overview of removal and replacement

Replacing any SCSI SE TO DIFF converter board cabling involves some minor disassembly of system assemblies. The following list provides a summary of the steps involved in the replacement process.

This list is intended for summary purposes only; detailed installation instructions are presented in the "Bulkhead to embedded drive SCSI cable replacement procedure" section on page 63.

- Step 1** Shut down the system.
- Step 2** Remove the front skin, filter, and Electromagnetic Interference (EMI) panels.
- Step 3** Disconnect the power cable and SCSI cable from the SCSI SE TO DIFF converter board.
- Step 4** Remove the Embedded Disk drive.
- Step 5** Remove SCSI SE TO DIFF converter board.
- Step 6** Connect the power cable and SCSI cable to the SCSI SE TO DIFF converter board.
- Step 7** Reboot the system and verify DAT drive operation.
- Step 8** Reinstall EMI panels, filter, and front skin.

Bulkhead to embedded drive SCSI cable replacement procedure

The "Bulkhead to embedded drive SCSI cable" (Part Number 601-680018-200) runs from J2 of the SCSI SE TO DIFF converter board to the rear of Embedded Disk drive to the EDIN connector as shown in Figure 13, "DDS-2 DAT drive cable block diagram," on page 32.

- Step 1** Shut down the system with the `/etc/shutdown` command.

The *time* argument can be used to schedule a timed shutdown or the keyword "now" can be used to shut down the system immediately.

```
/etc/shutdown -h now
```

- Step 2** Remove power to the system by turning the keyswitch on the operator panel to the OFF position.

Caution

Do not attempt to remove the SCSI SE TO DIFF converter board before removing power to the cabinet. Failure to remove power before removing the board damages electronic components on the assembly.

- Step 3** Remove the front cabinet skin by pulling from the top and bottom of the skin until it pops out as shown in Figure 28.
- Step 4** Remove the filter from the front of the chassis as shown in Figure 28.
- Step 5** Remove the front EMI panel by unfastening the screws securing the panel. See Figure 28.

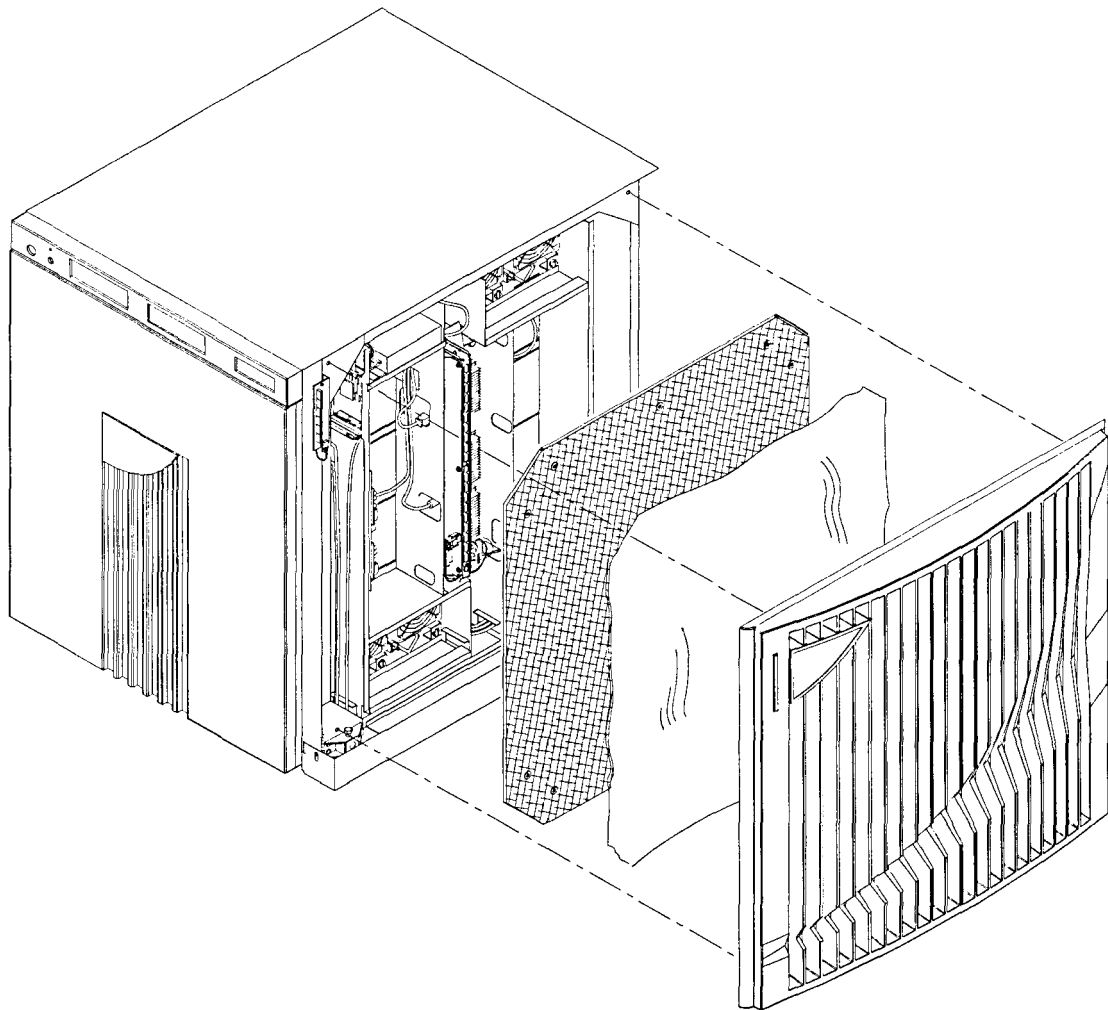

EXSM056
12/17/96

Figure 28 Removing front skin and EMI panel

Note

The Embedded Disk drive must be removed before the SCSI SE TO DIFF converter can be removed.

- Step 6** Disconnect P1 of the power cable (Part Number 604-040018-200) from the Embedded Disk drive power connector as shown in Figure 29.

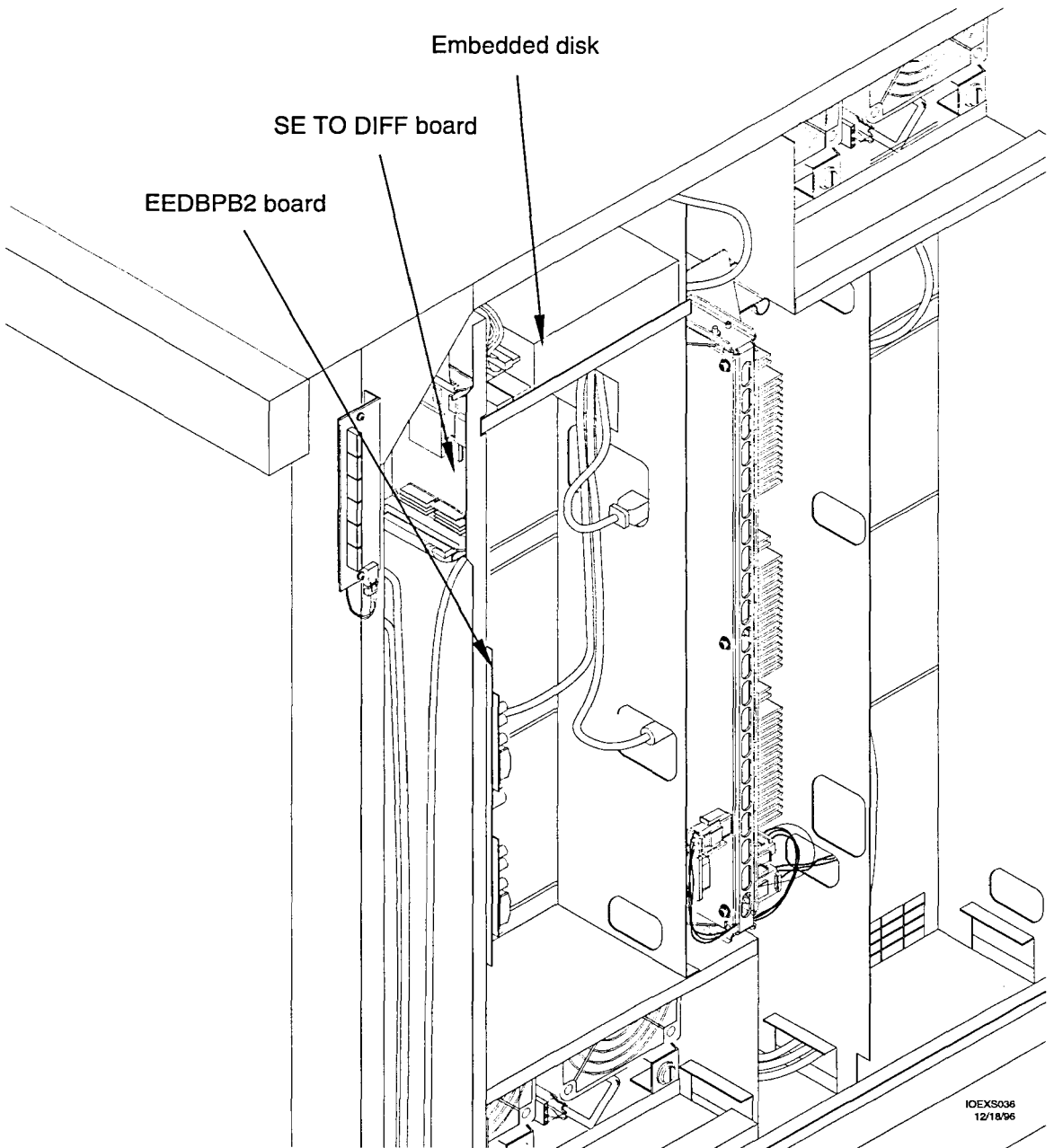

Figure 29 Embedded Disk drive configuration

- Step 7** Disconnect P3 of the SCSI cable (Part Number 601-680018-200) from the SCSI connector on the Embedded Disk.

- Step 8** Remove the two front bracket screws as shown in the close-up view in Figure 29.
- Step 9** Lift up on the Embedded Disk drive from under the front bracket and slide it out of its chassis location.
- Step 10** Place the Embedded Disk drive on a level work surface that contains a grounded static dissipating mat.
- Step 11** Disconnect P1 of the SCSI cable (Part Number 601-680015-200) from J1 of the SCSI SE TO DIFF converter board.
- Step 12** Disconnect P3 of the power cable (Part Number 604-060014-200) from J3 of the SCSI SE TO DIFF converter board.
- Step 13** Disconnect P2 of the SCSI cable (Part Number 601-680018-200) from J2 of the SCSI SE TO DIFF converter board.
- Step 14** The SCSI SE TO DIFF converter board (Part Number 201-000004-201) is mounted onto the bulkhead with four metal standoffs.
- Remove the SCSI SE TO DIFF converter board and its standoffs by removing the four screws on the right side of the bulkhead.
- Step 15** Place the SCSI SE TO DIFF converter board on a level work surface that contains a grounded static dissipating mat.

Note

This cable has been carefully dressed and routed. Use the original cable as a model when dressing and routing the replacement. Care should be taken to dress and route the replacement cable in the original manner.

- Step 16** Disconnect P4 of the SCSI cable (Part Number 601-680018-200) from the EDIN connector on the chassis bulkhead.
- Step 17** Cut the tie wrap(s) holding the "bulkhead to embedded drive SCSI cable" (Part Number 601-680018-200) in the chassis.
- Step 18** Using the old cable as a model carefully fold the new SCSI cable.
- Step 19** Secure the new SCSI cable into the chassis in the original cables position using a tie wrap.
- Step 20** Connect P3 of the SCSI cable (Part Number 601-680018-200) to the SCSI connector of the Embedded Disk drive.
- Step 21** Reattach the new SCSI SE TO DIFF converter board to the bulkhead using four screws.
- Step 22** Connect P3 of the power cable (Part Number 604-060014-200) to J3 of the SCSI SE TO DIFF converter board.
- Step 23** Connect P1 of the SCSI cable (Part Number 601-680015-200) to J1 of the SCSI SE TO DIFF converter board.

- Step 24** Connect P3 of the SCSI cable (Part Number 601-680018-200) to J2 of the SCSI SE TO DIFF converter board.
- Step 25** Replace the Embedded Disk drive by mating the center tab of the Embedded Disk drive rear bracket with the center hole of the chassis wall. Refer to Figure 29.
- Step 26** Insure that the front bracket slides into the frame slots provided and secure with two screws as shown.
- Step 27** Reattach P1 of the dc power cable (Part Number 604-040018-200) to the rear of the Embedded Disk drive.
- Step 28** Reattach P3 of the SCSI cable (Part Number 601-680018-200) to the SCSI connector of the Embedded Disk drive.
- Step 29** Reinstall the EMI panel, filter and front skin.

Power system removal and replacement

7

This chapter contains the removal and replacement procedures for the power board and cables for the DDS-2 DAT drive used in the Exemplar S-Class and X-Class Servers.

Precautions

Protect personnel and equipment when installing any Hewlett-Packard Company product by always taking proper precautions.

Electrostatic discharge (ESD)

Prepare an ESD safe work surface large enough to accommodate the DDS-2 DAT drive assembly.

Observe the electrostatic discharge procedures described in the "Electrostatic discharge protection" section on page xvii to prevent damage to the drive during installation.

Personal safety

Always insure that both the front panel and the power controller are turned off before removing or installing any components in the system.

Remove the front panel key after shutting the system down to prevent inadvertent power-on during installation.

dc power module removal and replacement

The following section provides instructions for the removal and replacement of the dc power module (Part Number 200-001058-201) in the Exemplar S-Class and X-Class Servers.

Tools required

The following tools are required to complete the procedures in this chapter.

- Phillips screwdriver
- Personal grounding system
- Static dissipating mat

Overview of removal and replacement

Replacing a dc power module (Part Number 200-001058-201) involves some minor disassembly of system assemblies. The following list provides a summary of the steps involved in the replacement process.

This list is intended for summary purposes only; detailed installation instructions are presented in the and the.

- Step 1** Shut down the system.
- Step 2** Remove the front skin, filter and Electromagnetic Interference (EMI) panels.
- Step 3** Remove the dc power module from the EEDPB2.
- Step 4** Install the new dc power module.
- Step 5** Reboot the system and verify DAT drive operation.
- Step 6** Install the EMI panel, filter, and front skin.

dc power module replacement procedure

The dc power module (Part Number 200-001058-201) is located in the POWER BOARD EXT FRONT position on the EEDPB2 board.

Step 1 Shut down the system with the `/etc/shutdown` command.

The *time* argument can be used to schedule a timed shutdown or the keyword "now" can be used to shut down the system immediately.

```
/etc/shutdown -h now
```

Step 2 Remove power to the system by turning the keyswitch on the operator panel to the OFF position.

Caution

Do not attempt to remove the dc power module before removing power to the cabinet. Failure to remove power before removing the DDS-2 DAT drive damages electronic components on the drive assembly.

- Step 3** Remove the front cabinet skin by pulling from the top and bottom of the skin until it pops out as shown in Figure 30.
- Step 4** Remove the filter from the front of the chassis as shown in Figure 30.
- Step 5** Remove the front EMI panel by unfastening the screws securing the panel. See Figure 30.

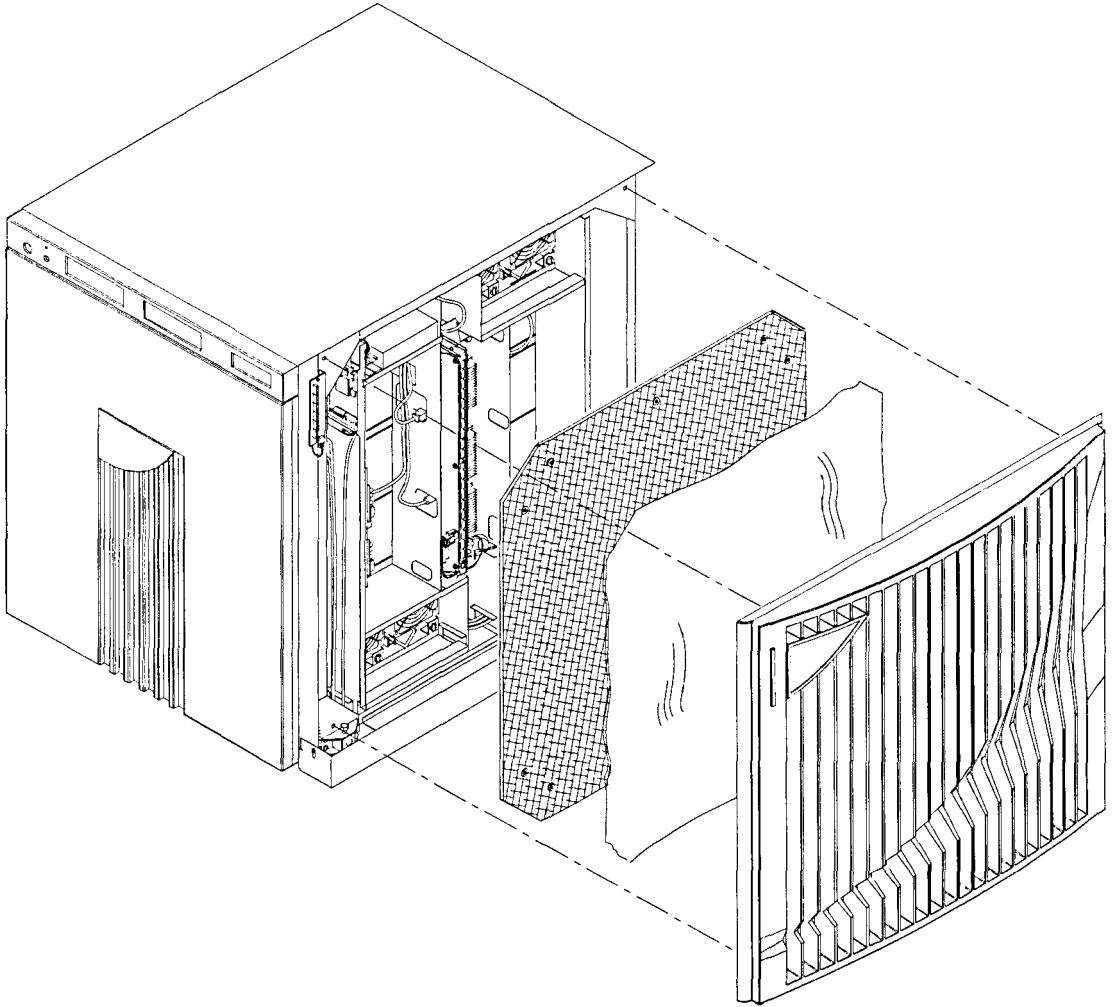

EXSM056
12/17/96

Figure 30 Removing front skin, filter, and EMI panel

Step 6 Locate the EEDPB2 mounted on the left chassis side panel just below the embedded disk drive. See Figure 31.

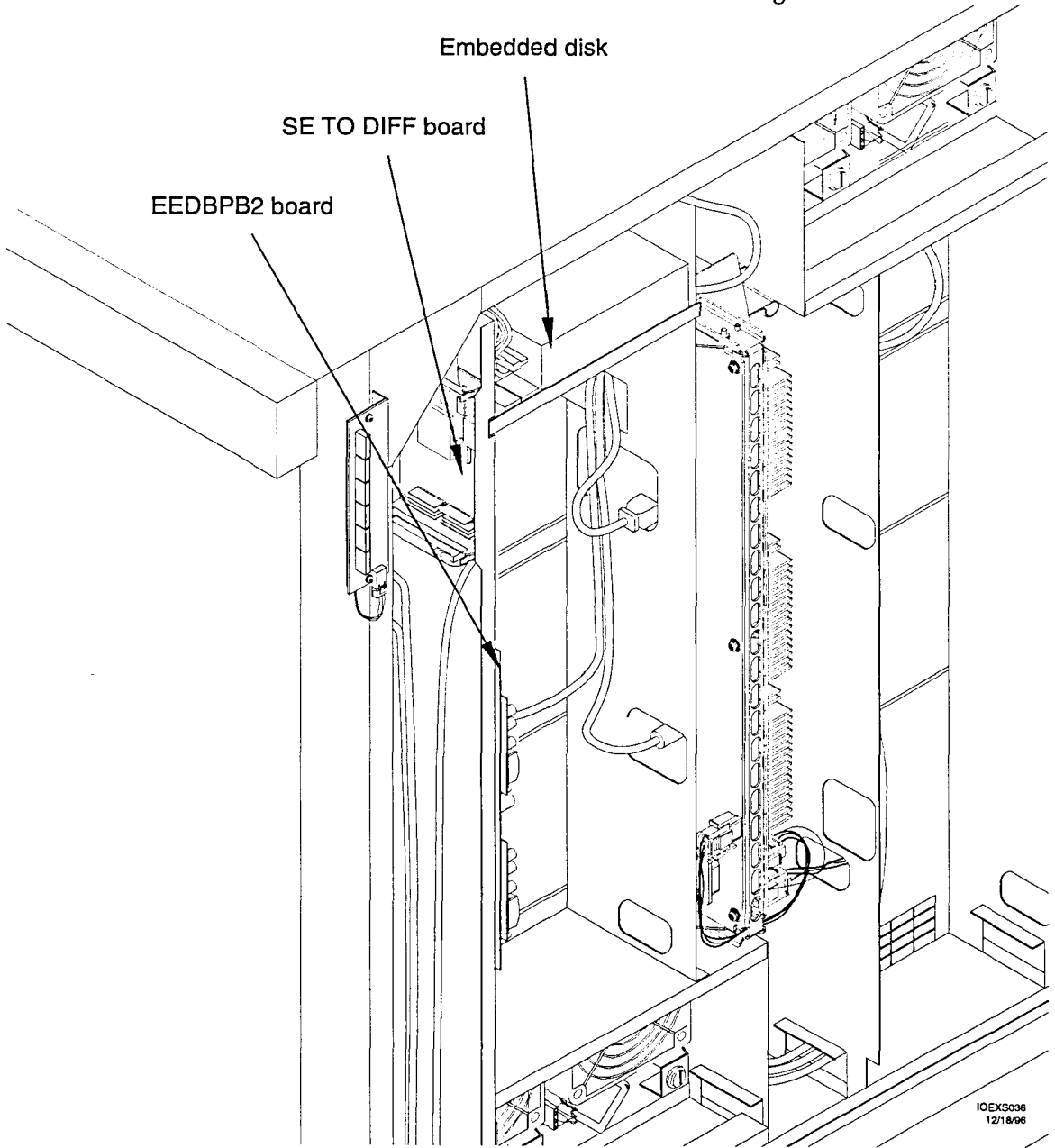

Figure 31 Left front chassis detail

- Step 7** Locate the dc power module (Part Number 200-001058-201) that is in the position marked "POWER BOARD EXT FRONT" on the EEDPB2 board. See Figure 32.
- Step 8** Turn the lockdowns 1/4 turn to release the dc power module.
- Step 9** Remove the dc power module from the EEDPB2 board.
- Step 10** Orient the new dc power module (Part Number 200-001058-201) as shown in Figure 32.

Caution

Do not install the dc power module incorrectly. Damage to the dc module will occur.

- Step 11** Mount the dc power module flush with the edge of the EEDPB2 to ensure that both connectors on the module mate properly.
- Step 12** Secure with the lockdowns as shown in Figure 32.
- Step 13** Install the EMI panel, filter and front skin.

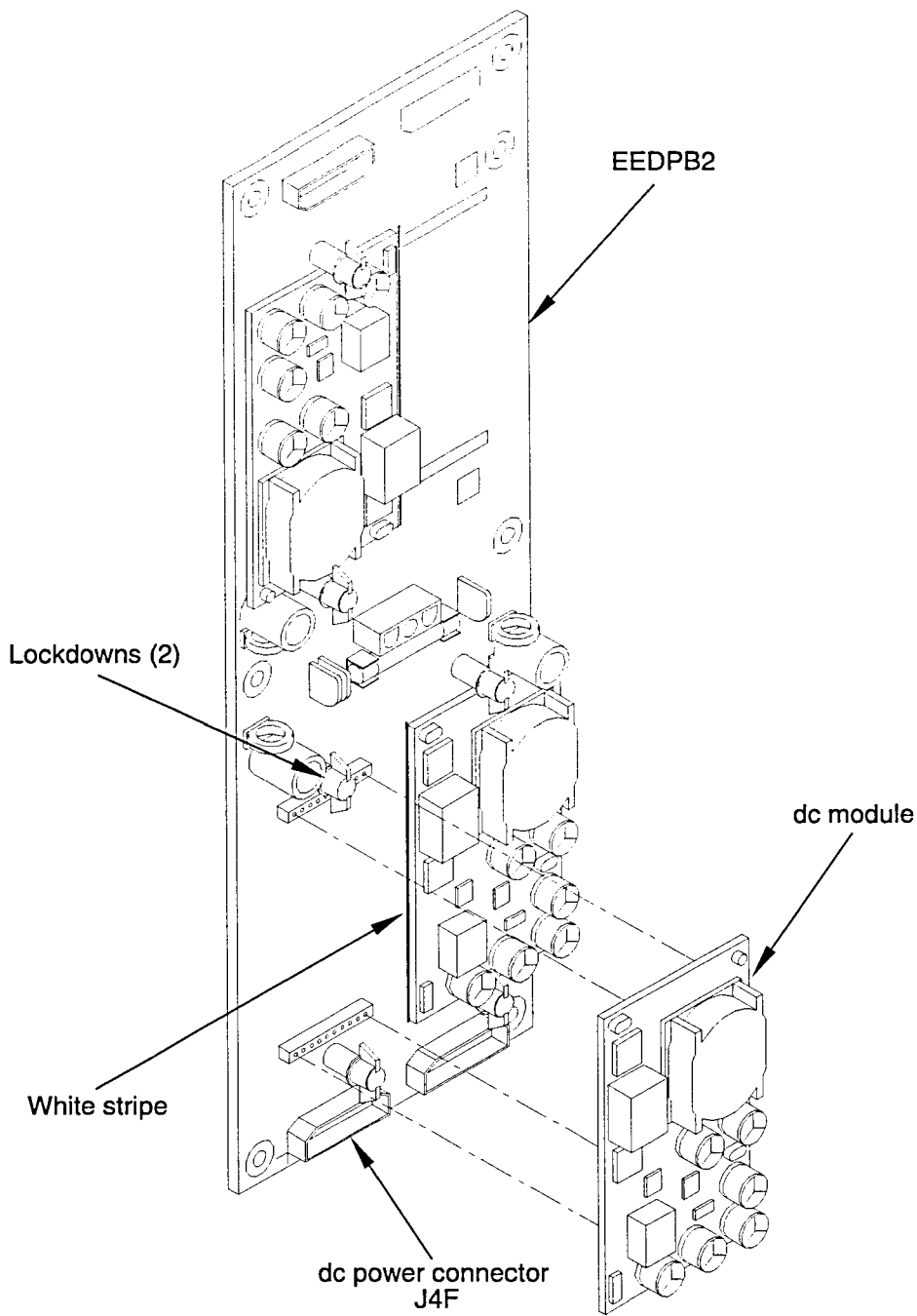

IOEXS046
12/16/96

Figure 32 Detail of EEDPB2 with dc power module

Power cable removal and replacement

The following section provides instructions for the removal and replacement of power cabling for the DDS-2 DAT drives in the Exemplar S-Class and X-Class Technical Server.

Note

Observe routing before removing any factory installed cable. Dress and route replacement cables in the original manner.

DAT drive 0 power cable

This section provides instructions for the removal and replacement of the DAT drive 0 power cable (Part Number 604-060014-200).

Tools required

The following tools are required to complete the procedures in this chapter.

- Phillips screwdriver
- Personal grounding system
- Static dissipating mat

Overview of removal and replacement

Replacing any DAT drive cabling involves some minor disassembly of system assemblies. The following list provides a summary of the steps involved in the replacement process.

This list is intended for summary purposes only; detailed installation instructions are presented in the "DAT drive 0 power cable replacement procedure" section on page 77.

- Step 1** Shut down the system.
- Step 2** Remove the front skin, left side skin, filter, and Electromagnetic Interference (EMI) panels.
- Step 3** Disconnect the power cable from the EDPB2 board and the SCSI SE TO DIFF converter.
- Step 4** Remove the LCD control panel.
- Step 5** Remove the DDS-2 DAT drive 0 cage assembly.
- Step 6** Remove the DDS-2 DAT drive 1 cage assembly or DAT drive blank panel if installed.

- Step 7** Remove the cable run plate.
- Step 8** Remove the cable.
- Step 9** Dress the new cable.
- Step 10** Replace the cable.
- Step 11** Replace the cable run plate.
- Step 12** Reinstall the DDS-2 DAT drive 0 cage assembly into the bay.
- Step 13** Reinstall the DDS-2 DAT drive 1 cage assembly or DAT drive blank panel into the bay.
- Step 14** Reinstall the LCD control panel.
- Step 15** Reboot the system and verify DAT drive operation.
- Step 16** Reinstall EMI panels, filter, front skin, and left side skin.

DAT drive 0 power cable replacement procedure

The DAT drive 0 power cable runs from J4F of the EEDPB2, to J3 of the SCSI SE TO DIFF converter to the rear of DAT drive 0, as shown in Figure 13, "DDS-2 DAT drive cable block diagram," on page 32.

- Step 1** Shut down the system with the `/etc/shutdown` command.

The *time* argument can be used to schedule a timed shutdown or the keyword "now" can be used to shut down the system immediately.

```
/etc/shutdown -h now
```

- Step 2** Remove power to the system by turning the keyswitch on the operator panel to the OFF position.

Caution

Do not attempt to remove the DAT drive before removing power to the cabinet. Failure to remove power before removing the DAT drive damages electronic components on the drive assembly.

- Step 3** Remove the front cabinet skin by pulling from the top and bottom of the skin until it pops out as shown in Figure 33.
- Step 4** Remove the filter from the front of the chassis as shown in Figure 33.
- Step 5** Remove the front EMI panel by unfastening the screws securing the panel. See Figure 33.

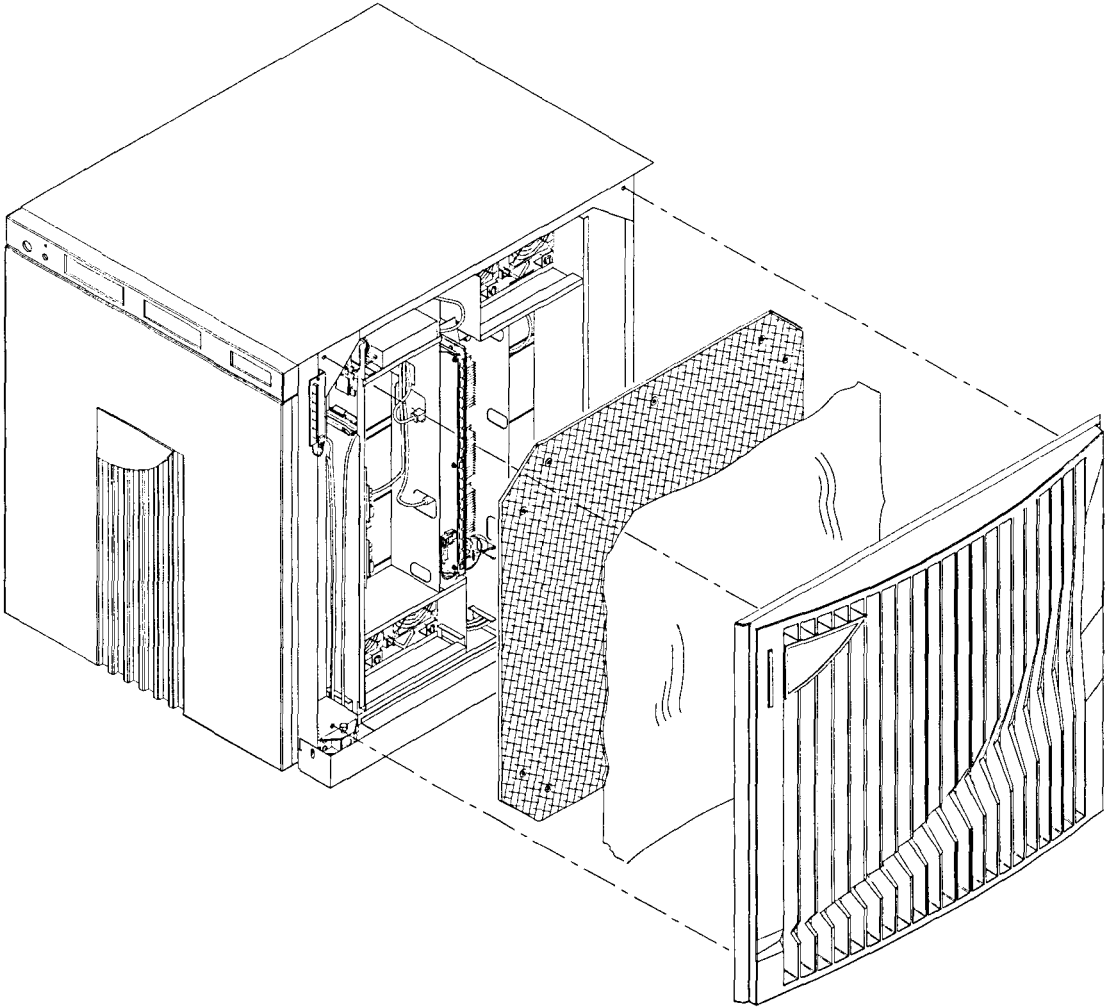

EXSM056
12/17/96

Figure 33 Removing front skin and EMI panel

- Step 6** Disconnect P2 of the DAT drive 0 power cable (604-060014-200) from J4F of the EEDPB2 board.
- Step 7** Disconnect P1 of the DAT drive 0 power cable (604-060014-200) from J3 of the SCSI SE TO DIFF converter board.

- Step 8** Remove the left side cabinet skin by pulling from the top and bottom of the skin until it pops out as shown in Figure 34.
- Step 9** Remove the EMI panel by unfastening the screws securing the panel. See Figure 34.

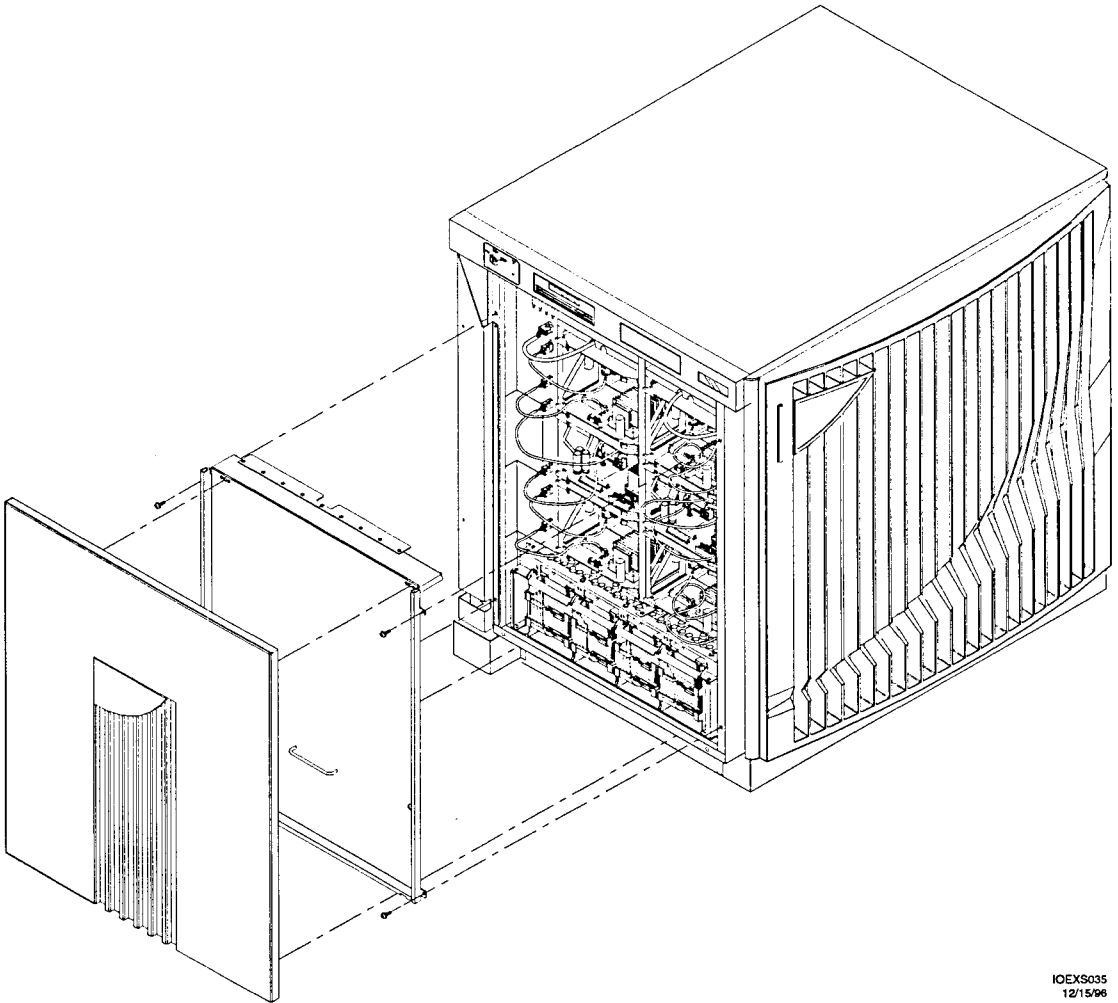

IOEXS035
12/15/96

Figure 34 Removing side skin and EMI panel

- Step 10** Remove the LCD control panel by removing four screws securing the panel. Carefully place the LCD control panel on top of the chassis.
- Step 11** Remove the two screws securing the DDS-2 DAT drive 0 cage assembly.

Step 12 Slide the DDS-2 DAT drive 0 cage assembly from the DAT drive bay. See Figure 35.

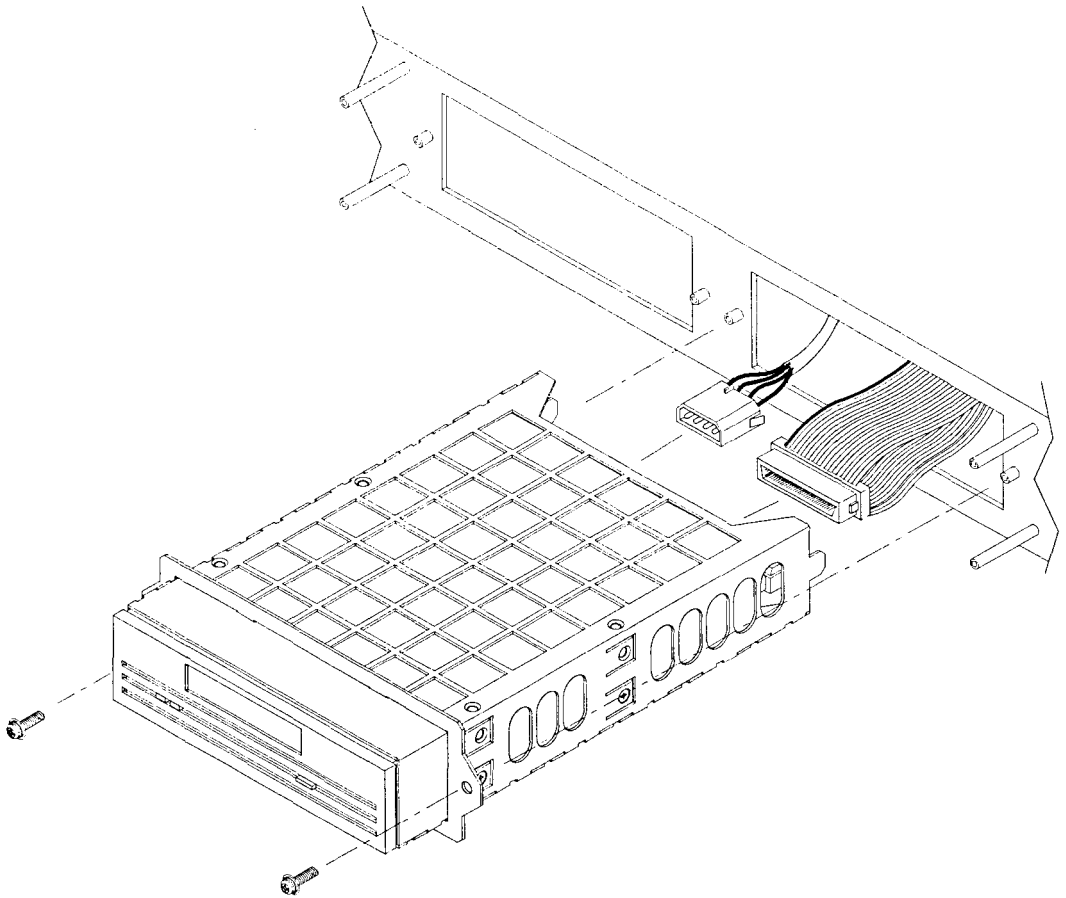

IOEXS041
12/10/96

Figure 35 Removing the DAT drive from the drive bay

- Step 13** Disconnect the SCSI cable from the rear of the DDS-2 DAT drive cage assembly.
- Step 14** Disconnect the power cable from the rear of the DDS-2 DAT drive cage assembly.
- Step 15** Place the DDS-2 DAT drive on a level work surface that contains a grounded static dissipating mat.

Step 16 Repeat steps 10 through 14 for DDS-2 DAT drive 1 if installed. Otherwise remove the DAT drive blank panel from the chassis by removing the two screws that secure the panel as shown in Figure 36.

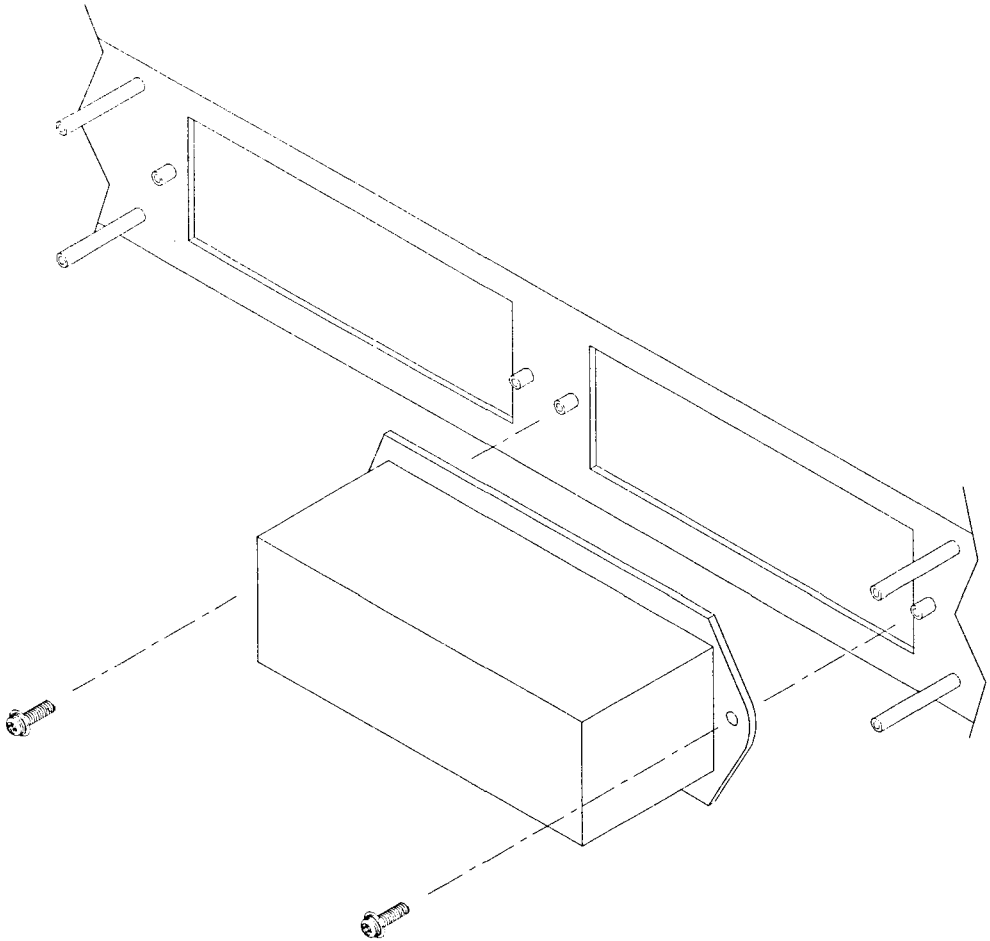
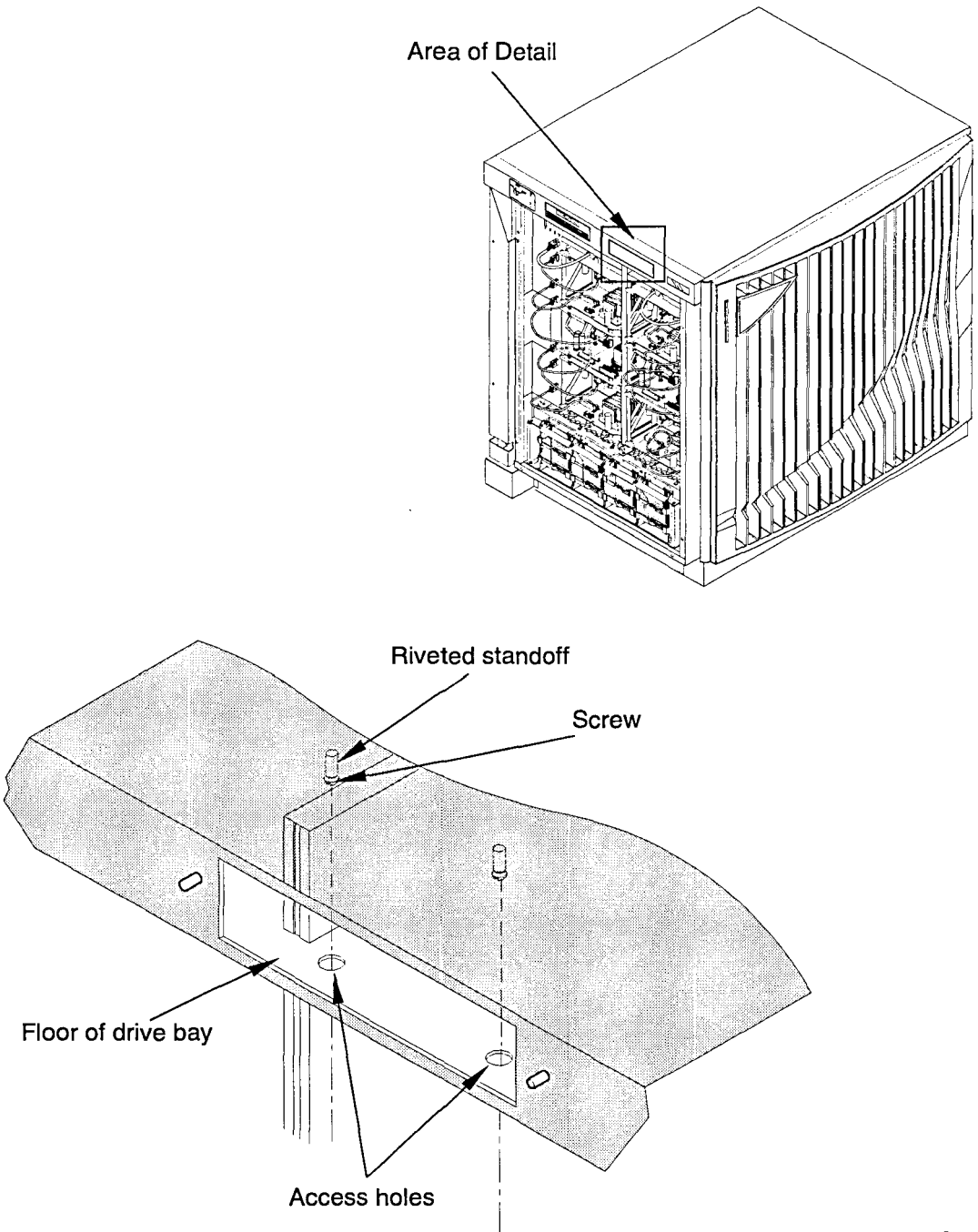

Figure 36 Removing the DAT drive blank panel

Step 17 Remove the cable run plate by loosening the two screws securing it to the top of the DAT drive bay. Two screwdriver access holes are situated in the floor of the DAT drive bay. See Figure 37.

Slide the plate toward the rear of the bay and down to release it.



IOEXS034
12/11/96

Figure 37 DAT drive bay

- Step 18** Lay the plate and cables in the floor of the drive bay.
- Step 19** Remove the DAT drive 0 power cable (Part Number 604-060014-200) from the drive bay. Carefully feed the ends of the cable that were connected to the EEDPB2 and SCSI SE TO DIFF boards through the chassis as you extract the cable.
- Step 20** Feed the new power cable (Part Number 604-060014-200) through the DAT drive bay bulkheads and attach P2 to J4F of the EEDPB2 board and P3 to J3 of the SCSI SE TO DIFF converter board.
- Step 21** Place the new power cable into the DAT drive bay so that the power cable lies on the cable run plate.
- Step 22** Install the cable run plate in the DAT drive bay by pressing it up onto both screws in the top of the bay and sliding the plate toward the front of the bay.
- Step 23** Secure the cable run plate by tightening the two screws securing it to the top of the DAT drive bay. Two screwdriver access holes are situated in the floor of the DAT drive bay. See Figure 37.
- Step 24** Attach the SCSI cable to the back of the DDS-2 DAT drive. See Figure 35.
- Step 25** Attach the power cable to the back of the DDS-2 DAT drive. See Figure 35.
- Step 26** Slide the DDS-2 DAT drive cage assembly into the drive bay. The SCSI cable and power supply cable should fold up and over the top of the drive and lay flat.
- Step 27** Mate the tabs on each side of the DDS-2 DAT drive cage assembly with the corresponding slots in the back wall of the drive bay.
- Step 28** Secure the DDS-2 DAT drive cage assembly with two screws.
- Step 29** Repeat steps 24 through 28 for DDS-2 DAT drive 1 if installed, otherwise, replace the DAT drive blank panel by using two screws to secure the panel as shown in Figure 36.
- Step 30** Reinstall the LCD control panel using four screws.
- Step 31** Reinstall the EMI panels, filter, and side skins.

DAT drive 1 power cable

This section provides instructions for the removal and replacement of the DAT drive 1 power cable (Part Number 604-060018-201).

Tools required

The following tools are required to complete the procedures in this chapter.

- Phillips screwdriver
- Personal grounding system
- Static dissipating mat

Overview of removal and replacement

Replacing any DAT drive cabling involves some minor disassembly of system assemblies. The following list provides a summary of the steps involved in the replacement process.

This list is intended for summary purposes only; detailed installation instructions are presented in the "DAT drive 1 power cable replacement procedure" section on page 85.

- Step 1** Shut down the system.
- Step 2** Remove the front skin, left side skin, filter, and Electromagnetic Interference (EMI) panels.
- Step 3** Disconnect the power cable from the EEDPB2.
- Step 4** Remove the LCD control panel.
- Step 5** Remove the DDS-2 DAT drive 1 cage assembly.
- Step 6** Remove the cable run plate.
- Step 7** Remove the power cable.
- Step 8** Replace the power cable.
- Step 9** Replace the cable run plate.
- Step 10** Reinstall the DDS-2 DAT drive 0 cage assembly into the bay.
- Step 11** Reinstall the DDS-2 DAT drive 1 cage assembly or DAT drive blank panel into the bay.
- Step 12** Reinstall the control panel.
- Step 13** Reboot the system and verify DAT drive operation.

Step 14 Reinstall EMI panels, filter, front skin, and left side skin.

DAT drive 1 power cable replacement procedure

The DAT drive 1 power cable runs from J3F of the EEDPB2, to the rear of DAT drive 1, as shown in Figure 13, "DDS-2 DAT drive cable block diagram," on page 32.

Step 1 Shut down the system with the `/etc/shutdown` command.

The *time* argument can be used to schedule a timed shutdown or the keyword "now" can be used to shut down the system immediately.

```
/etc/shutdown -h now
```

Step 2 Remove power to the system by turning the keyswitch on the operator panel to the OFF position.

Caution

Do not attempt to remove the DAT drive before removing power to the cabinet. Failure to remove power before removing the DAT drive damages electronic components on the drive assembly.

- Step 3** Remove the front cabinet skin by pulling from the top and bottom of the skin until it pops out as shown in Figure 38.
- Step 4** Remove the filter from the front of the chassis as shown in Figure 38.
- Step 5** Remove the front EMI panel by unfastening the screws securing the panel. See Figure 38.

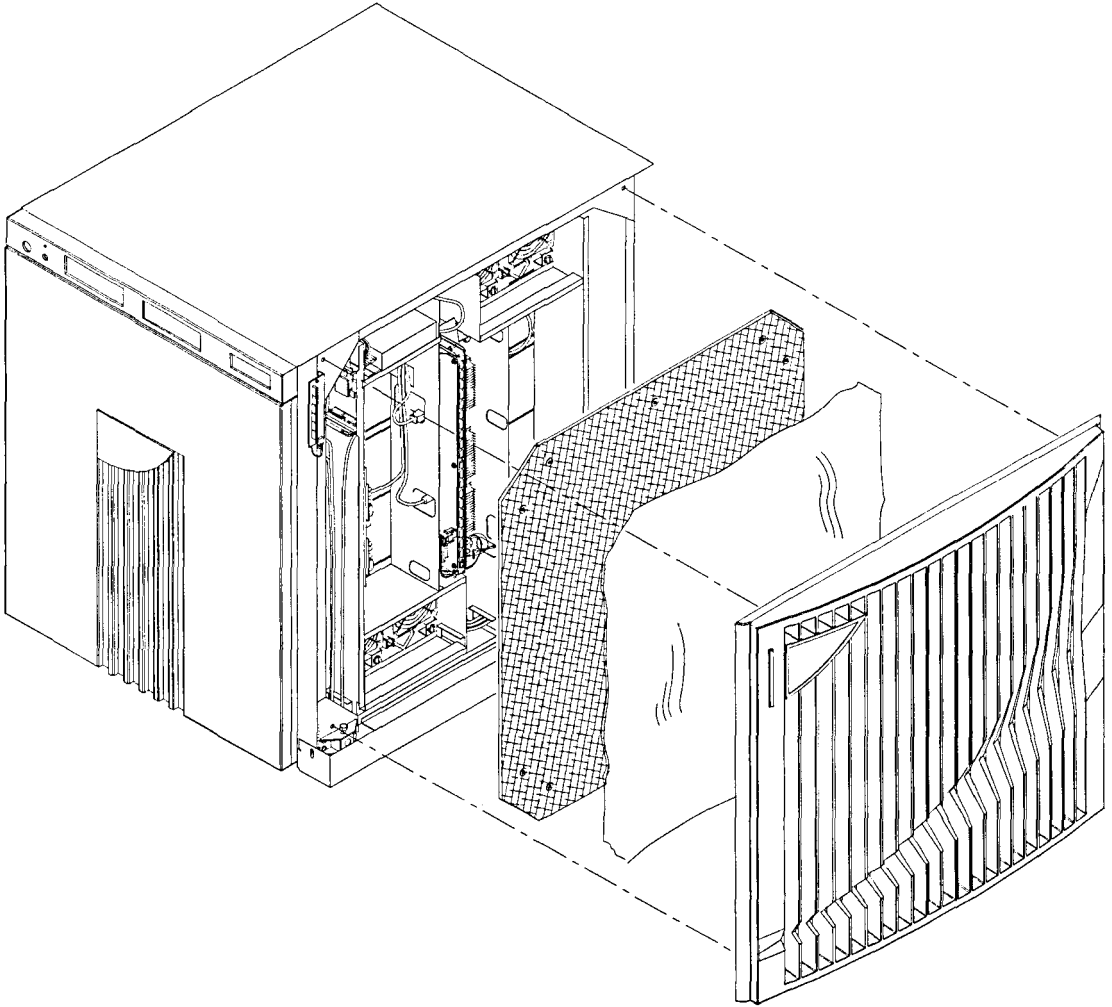

EXSM056
12/17/96

Figure 38 Removing front skin and EMI panel

- Step 6** Disconnect P3 of the DAT drive 1 power cable (604-040018-201) from J3F of the EEDPB2 board.

- Step 7** Remove the left side cabinet skin by pulling from the top and bottom of the skin until it pops out as shown in Figure 39.
- Step 8** Remove the EMI panel by unfastening the screws securing the panel. See Figure 39.

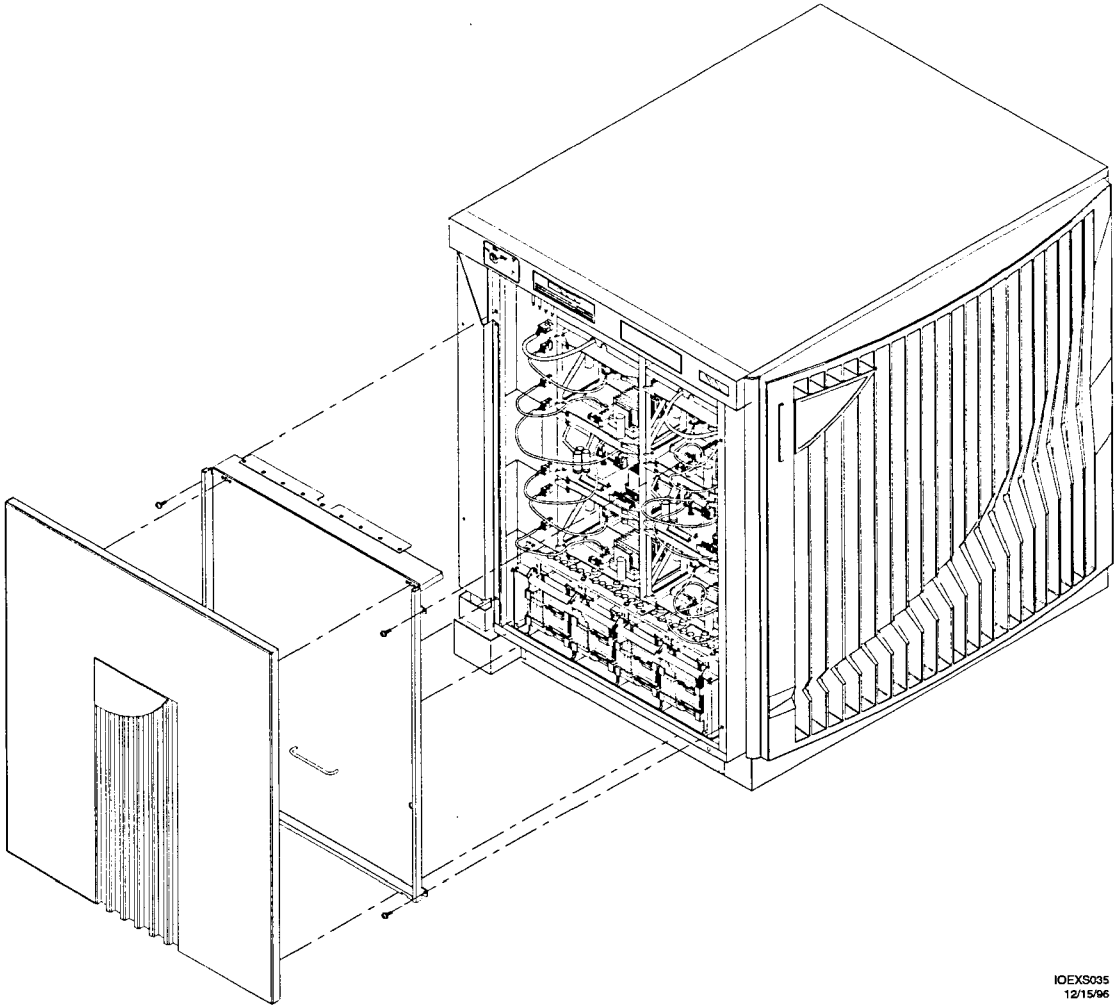

IOEXS035
12/15/96

Figure 39 Removing side skin and EMI panel

- Step 9** Remove the LCD control panel by removing four screws securing the panel. Carefully place the LCD control panel on top of the chassis.
- Step 10** Remove the two screws securing the DDS-2 DAT drive 1 cage assembly.

Step 11 Slide the DDS-2 DAT drive 1 cage assembly from the DAT drive bay. See Figure 40.

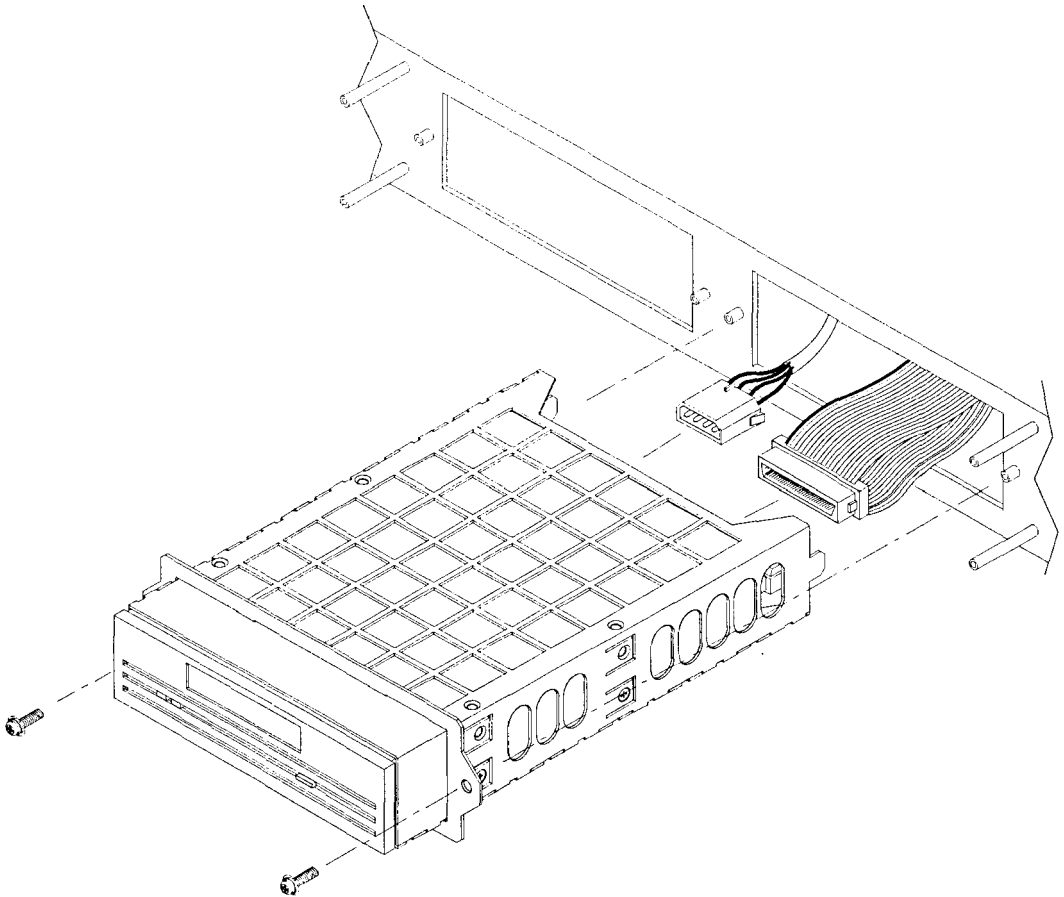

IOEXS041
12/10/96

Figure 40 Removing the DAT drive from the drive bay

- Step 12** Disconnect the SCSI cable from the rear of the DDS-2 DAT drive cage assembly.
- Step 13** Disconnect the power cable from the rear of the DDS-2 DAT drive cage assembly.
- Step 14** Place the DDS-2 DAT drive on a level work surface that contains a grounded static dissipating mat.
- Step 15** Remove the cable run plate by loosening the two screws securing it to the top of the DAT drive bay. Two screwdriver access holes are situated in the floor of the DAT drive bay. See Figure 41.
Slide the plate toward the rear of the bay and down to release it.

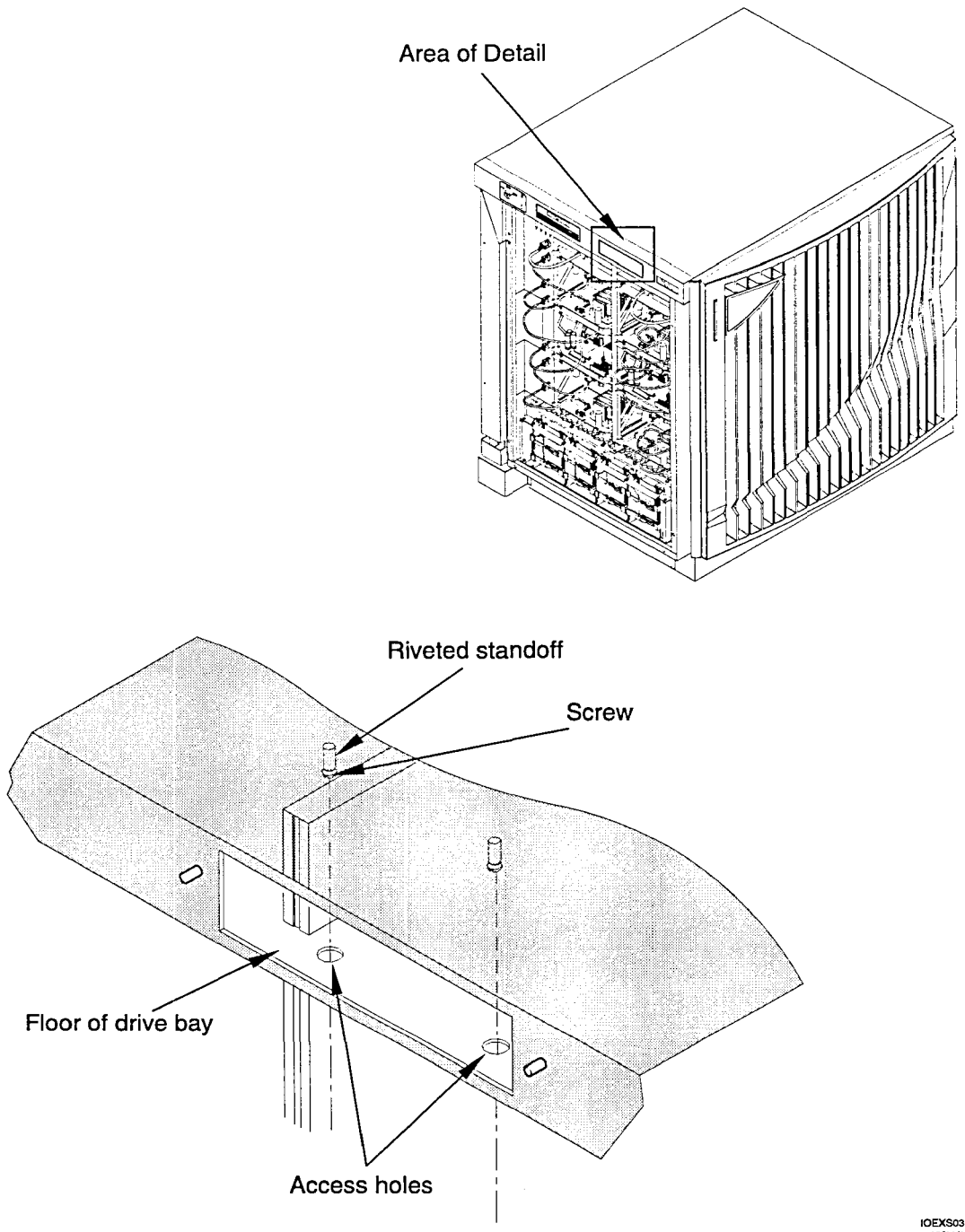

IOEXS034
12/11/96

Figure 41 DAT drive bay

- Step 16** Lay the plate and cables in the floor of the drive bay.
- Step 17** Remove the DAT drive power cable from the drive bay.
Carefully feed the P2 end of the cable that was connected to J3F of the EEDPB2 through the chassis as you extract the cable.
- Step 18** Feed P2 the new power cable (Part Number 604-040018-201) through the DAT drive bay bulkheads and attach to J3F of the EEDPB2 board.
- Step 19** Place the new power cable into the DAT drive bay so that the power cable lies on the cable run plate.
- Step 20** Install the cable run plate in the DAT drive bay by pressing it up onto both screws in the top of the bay and sliding the plate toward the front of the bay.
- Step 21** Secure the cable run plate by tightening the two screws securing it to the top of the DAT drive bay. Two screwdriver access holes are situated in the floor of the DAT drive bay. See Figure 41.
- Step 22** Attach the SCSI cable to the back of the DDS-2 DAT drive. See Figure 40.
- Step 23** Attach the power cable to the back of the DDS-2 DAT drive. See Figure 40.
- Step 24** Slide the DDS-2 DAT drive cage assembly into the drive bay. The SCSI cable and power supply cable should fold up and over the top of the drive and lay flat.
- Step 25** Mate the tabs on each side of the DDS-2 DAT drive cage assembly with the corresponding slots in the back wall of the drive bay.
- Step 26** Secure the DDS-2 DAT drive cage assembly with two screws.
- Step 27** Reinstall the LCD control panel using four screws.
- Step 28** Reinstall the EMI panels, filter, and side skins.

SCSI SE TO DIFF converter removal and replacement

8

This chapter contains the removal and replacement procedures for the SCSI SE TO DIFF converter board used in the Exemplar S-Class and X-Class Servers.

Precautions

Protect personnel and equipment when installing any Hewlett-Packard Company product by always taking proper precautions.

Electrostatic discharge (ESD)

Prepare an ESD safe work surface large enough to accommodate the DDS-2 DAT drive assembly.

Observe the electrostatic discharge procedures described in the "Electrostatic discharge protection" section on page xvii to prevent damage to the drive during installation.

Personal safety

Always insure that both the front panel and the power controller are turned off before removing or installing any components in the system.

Remove the front panel key after shutting the system down to prevent inadvertent power-on during installation.

SCSI SE TO DIFF converter board removal and replacement

The following section provides instructions for the removal and replacement of the SCSI SE TO DIFF converter (Part Number 201-000004-201) in the Exemplar S-Class and X-Class Servers.

Tools required

The following tools are required to complete the procedures in this chapter.

- Phillips screwdriver
- Personal grounding system
- Static dissipating mat

Overview of removal and replacement

Replacing a SCSI SE TO DIFF involves some minor disassembly of system assemblies. The following list provides a summary of the steps involved in the replacement process.

This list is intended for summary purposes only; detailed installation instructions are presented in the "Removing the SCSI SE TO DIFF converter board" section on page 93 and the "Installing the SCSI SE TO DIFF converter board." section on page 97.

- Step 1** Shut down the system.
- Step 2** Remove the front skin, filter, and Electromagnetic Interference (EMI) panels.
- Step 3** Disconnect the power cable and SCSI cable from the SCSI SE TO DIFF converter board.
- Step 4** Remove the Embedded Disk drive.
- Step 5** Remove SCSI SE TO DIFF converter board.
- Step 6** Remove the 68-pin to 50-pin adaptors from of the SCSI SE TO DIFF converter.
- Step 7** Install the 68-pin to 50-pin adaptors onto the new SCSI SE TO DIFF converter board.
- Step 8** Connect the power cable and SCSI cable to the SCSI SE TO DIFF converter board.
- Step 9** Reboot the system and verify DAT drive operation.
- Step 10** Reinstall EMI panels, filter, and front skin.

Removing the SCSI SE TO DIFF converter board

To remove the SCSI SE TO DIFF converter board (Part Number 201-000004-201), perform the following steps:

- Step 1** Shut down the system with the `/etc/shutdown` command.

The *time* argument can be used to schedule a timed shutdown or the keyword "now" can be used to shut down the system immediately.

```
/etc/shutdown -h now
```

- Step 2** Remove power to the system by turning the keyswitch on the operator panel to the OFF position.

Caution

Do not attempt to remove the SCSI SE TO DIFF converter board before removing power to the cabinet. Failure to remove power before removing the board damages electronic components on the assembly.

- Step 3** Remove the front cabinet skin by pulling from the top and bottom of the skin until it pops out as shown in Figure 42.
- Step 4** Remove the filter from the front of the chassis as shown in Figure 42.
- Step 5** Remove the front EMI panel by unfastening the screws securing the panel. See Figure 42.

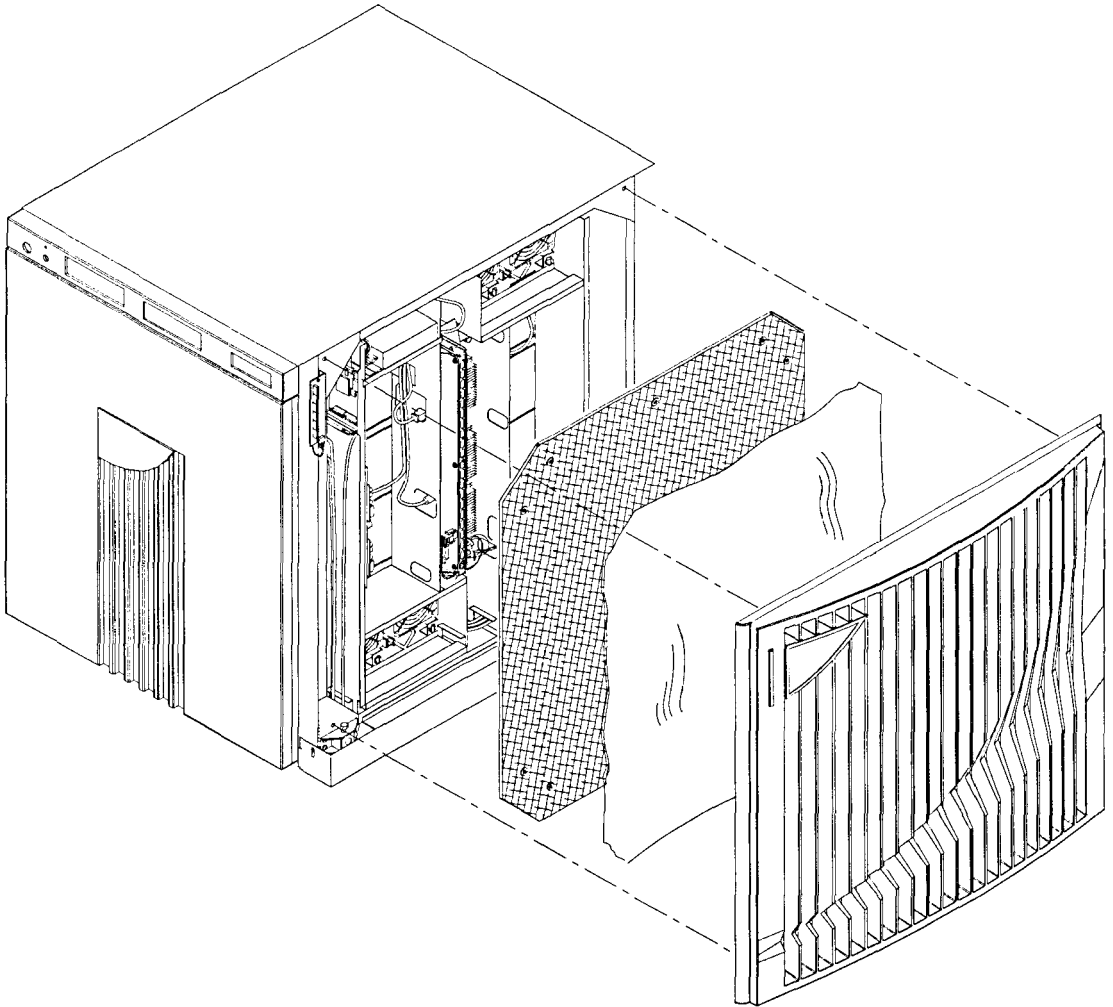

EXSM056
12/17/96

Figure 42 Removing front skin and EMI panel

Note

The Embedded Disk drive must be removed before the SCSI SE TO DIFF converter can be replaced.

- Step 6** Disconnect P1 of the power cable (Part Number 604-040018-200) from the rear of the Embedded Disk drive power connector as shown in Figure 43.

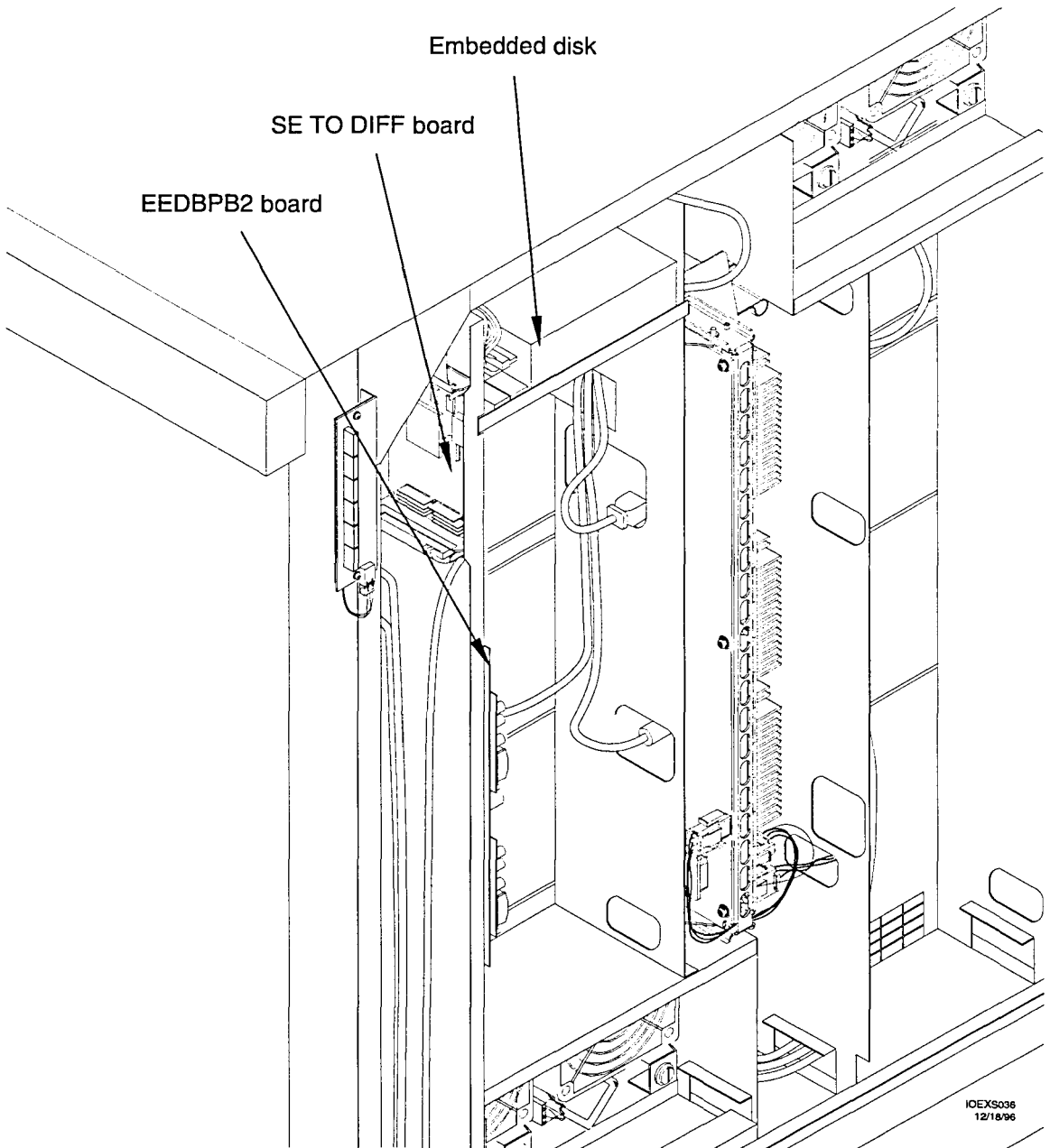

Figure 43 Embedded Disk drive configuration

- Step 7** Disconnect P3 of the SCSI cable (Part Number 601-680018-200) from the SCSI connector on the Embedded Disk.

- Step 8** Remove the two front bracket screws as shown in the close-up view in Figure 43.
- Step 9** Lift up on the Embedded Disk drive from under the front bracket and slide it out of its chassis location.
- Step 10** Disconnect P1 of the SCSI cable (Part Number 601-680015-200) from J1 of the SCSI SE TO DIFF converter board.
- Step 11** Disconnect P3 of the power cable (Part Number 604-060014-200) from J3 of the SCSI SE TO DIFF converter board.
- Step 12** Disconnect P2 of the SCSI cable (Part Number 601-680018-200) from J2 of the SCSI SE TO DIFF converter board.
- Step 13** The SCSI SE TO DIFF converter board is mounted onto the bulkhead with four metal standoffs.
- Remove the SCSI SE TO DIFF converter board and its standoffs by removing the four screws on the right side of the bulkhead.
- Step 14** Place the SCSI SE TO DIFF converter board on a level work surface that contains a grounded static dissipating mat.

Installing the SCSI SE TO DIFF converter board.

To reinstall the SCSI SE TO DIFF converter board, use the following procedure:

- Step 1** Verify jumper configuration on the new board. See Table 8 for jumper settings and Figure 44 for SCSI SE TO DIFF jumper locations.

Figure 44 SCSI SE TO DIFF converter (201-000004-201) jumpers

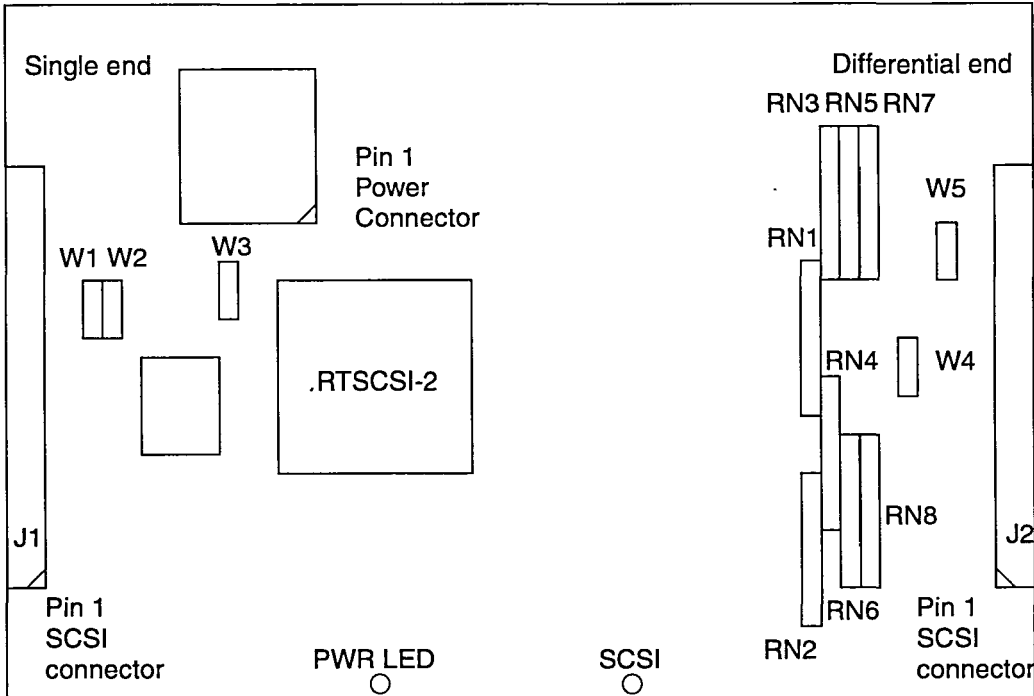

Table 8 Option jumper settings for SE TO DIFF converter board

Jumper	Default configuration ¹
W1	ON
W2	OFF
W3	ON
W4	OFF
W5	ON
RN1-4	Removed
RN5-8	Removed

1. Default configuration is subject to change. See Rancho SE-to-Diff SCSI Converter Model RTSDA-S2 Configuration Document 201-000004-600

- Step 2** Remove the 68-pin to 50-pin adapter (Part Number 301-000154-002) from J1 of the SCSI SE TO DIFF converter.
- Step 3** Install the 68-pin to 50-pin adaptor on J1 of the new SCSI SE TO DIFF converter board (Part Number 201-000004-201).
- Step 4** Remove the 68-pin to 50-pin adapter (Part Number 301-000154-002) from J2 of the SCSI SE TO DIFF converter.
- Step 5** Install the 68-pin to 50-pin adaptor on J2 of the new SCSI SE TO DIFF converter board (Part Number 201-000004-201).
- Step 6** If the new SCSI SE TO DIFF converter board did not come with standoffs already installed, transfer the standoffs from the old SCSI SE TO DIFF converter board to the new board.
- Step 7** Attach the new SCSI SE TO DIFF converter board to the bulkhead using four screws.
- Step 8** Attach P1 of the SCSI cable (Part Number 601-680018-200) to J1 of the SCSI SE TO DIFF converter board.
- Step 9** Attach P3 of the power cable (Part Number 604-060014-200) to J3 of the SCSI SE TO DIFF converter board.
- Step 10** Attach P2 of the SCSI cable (Part Number 601-680015-200) to J2 of the SCSI SE TO DIFF converter board.
- Step 11** Replace the Embedded Disk drive by mating the center tab of the Embedded Disk drive rear bracket with the center hole of the chassis wall. Refer to Figure 43.
- Step 12** Insure that the front bracket slides into the frame slots provided and secure with two screws as shown in Figure 43.
- Step 13** Reattach P1 of the dc power cable (Part Number 604-040018-200) to the rear of the Embedded Disk drive.
- Step 14** Reattach P3 of the SCSI cable (Part Number 601-680018-200) to the SCSI connector of the Embedded Disk drive.
- Step 15** Reinstall the EMI panel, filter, and front skin.

Index

B

block diagram 32
BOM 24
BOP 24
buttons
 Unload 24

C

cables
 block diagram 32
 DAT drive 0 power cable 77
 DAT drive 0 SCSI cable 40
 DAT drive 0 to 1 SCSI jumper cable 48, 49
 DAT drive 1 power cable 85
 DAT drive 1 SCSI cable 55
 factory installed 32, 39, 62, 76
 location 32
 removal and replacement 39
cartridges
 cleaning 27
 cleaning cartridge 27
 DDS 23
 DDS Media Recognition System 24
 inserting 23
 labels, proper location 23
 media caution signal 22
 problems 25, 26
 removing 24
cleaning cartridge 27
cleaning heads
 drives 27
condensation 28
configuration
 jumpers 4

D

damage claims 9
data compression 4
dc power module 70
 installation 17
 location 18, 75
 replacement 71
dc power requirements 3
DDS Media Recognition System 24
DDS-2 DAT drive

 installing 38
 installing second drive 13
device path 19
drive blank panel 15

E

EEDPB2 18
eject button 21
electrostatic discharge protection xix
 antistatic packaging xix
 ground xix
Embedded Disk drive 95
ENABLE MEDIA REMOVAL 24

F

FCC notice xviii
front panel 21
FRU list 33

H

head cleaning
 drives 27
headings 25
 first level, H1 25
heads
 cleaning 27

I

indicator LEDs 21
 cassette status 22
 drive status 22
 error conditions 21
inserting cartridges 23
inspection 9
installation
 problems 25

J

jumpers 4

L

loading
cartridges 23
sequence 24

M

Media Caution signal 27
media caution signal 22
mkmap 19
model number 1

P

part number
secondary DDS-2 DAT drive 12
part numbers
FRU list 33
terminators 32
physical-unit mapping 19
power cable
drive 0 77
drive 1 85
power connector
location 4
pins 4
power requirements 3
PREVENT MEDIA REMOVAL 24
product type 1

S

screwdriver access 45
SCSI cables
DAT drive 0 40
DAT drive 1 55
SCSI ID 5
first DDS-2 DAT 5
second DDS-2 DAT 5
SCSI SE TO DIFF converter 92
Embedded Disk drive removal 94
jumper settings 97
removal and replacement 70, 92
second DDS-2 DAT drive 13
self test 4
setting jumpers
option 4
SCSI ID 5
show-devs 19
show-map 20
specifications

cartridge 2
drive jumpers 4
electrical 6
environmental requirements 2
performance 2
physical 2

T

temperature 28
terminators 33
troubleshooting
cartridges 25, 26
general 25

U

Unload button 24
disabled 24
unloading
cartridges 23
unpacking 9



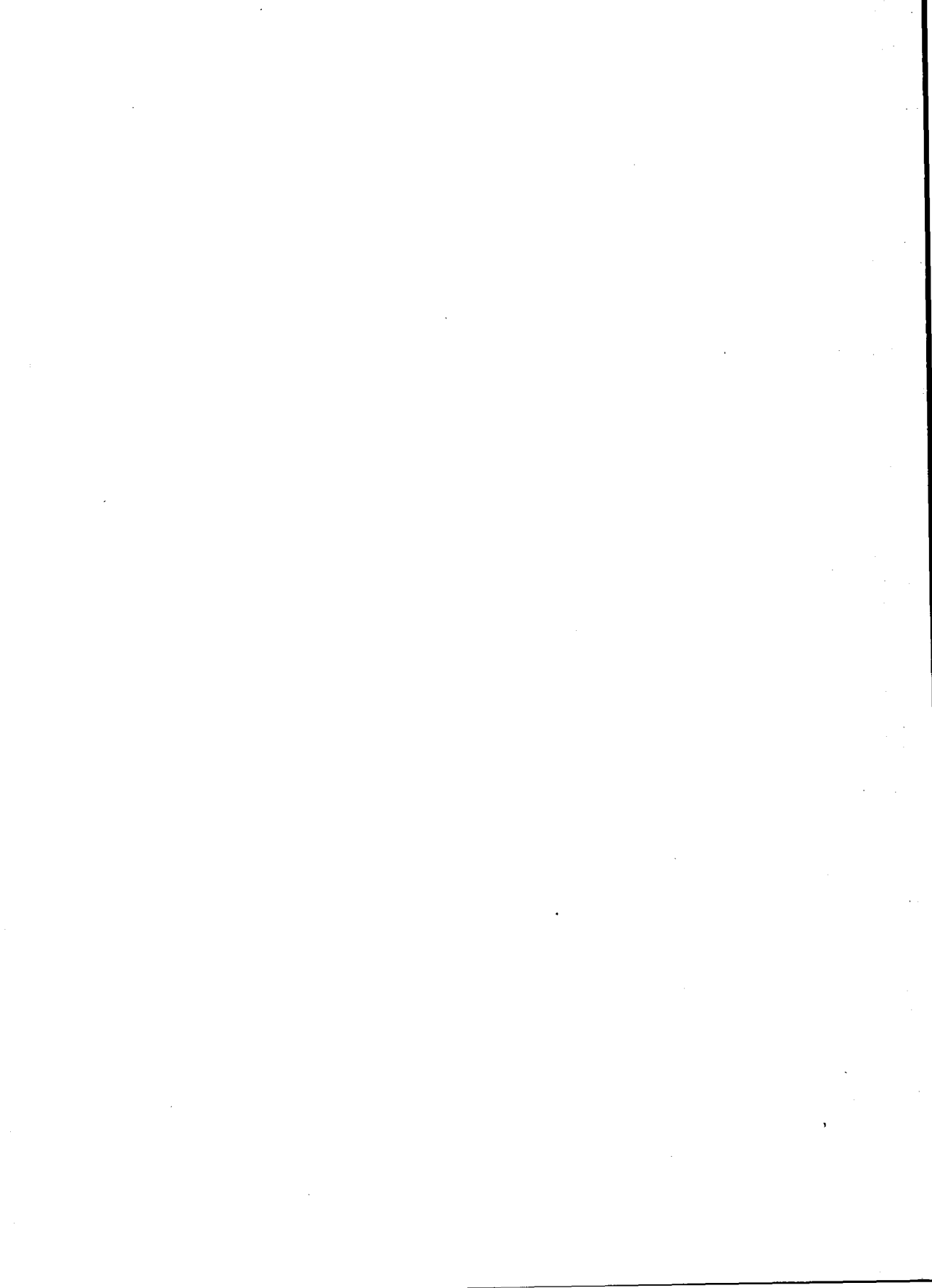





CONVEX
PRESS

A4716-90014

